

**AIRCRAFT MAINTENANCE MANUAL - PART I  
SYSTEM DESCRIPTION SECTION**

**CHAPTER 12 – SERVICING**

**LIST OF EFFECTIVE PAGES**

<b>Ch-Se-Su</b>	<b>Effectivity</b>	<b>Page</b>	<b>Date</b>	<b>Ch-Se-Su</b>	<b>Effectivity</b>	<b>Page</b>	<b>Date</b>
12 - Effective Pages				12-20-00	ALL	1	Jan 15/2005
						2	Jan 15/2005
ALL		1	Jan 15/2005			3	Jan 15/2005
						4	Jan 15/2005
12 - Contents	ALL	1	Jan 15/2005			5	Jan 15/2005
		2	Jan 15/2005			6	Jan 15/2005
						7	Jan 15/2005
12-00-00	ALL	1	Jan 15/2005			8	Jan 15/2005
		2	Jan 15/2005			9	Jan 15/2005
						10	Jan 15/2005
12-10-00	ALL	1	Jan 15/2005			11	Jan 15/2005
						12	Jan 15/2005
12-11-00	ALL	1	Jan 15/2005			13	Jan 15/2005
		2	Jan 15/2005			14	Jan 15/2005
		3	Jan 15/2005				
				12-30-00	ALL	1	Jan 15/2005
12-12-00	ALL	1	Jan 15/2005				
		2	Jan 15/2005				
		3	Jan 15/2005				
		4	Jan 15/2005				
12-13-00	ALL	1	Jan 15/2005				
		2	Jan 15/2005				
		3	Jan 15/2005				
		4	Jan 15/2005				
		5	Jan 15/2005				
		6	Jan 15/2005				
12-16-00	ALL	1	Jan 15/2005				
		2	Jan 15/2005				
12-18-00	ALL	1	Jan 15/2005				
		2	Jan 15/2005				
		3	Jan 15/2005				
		4	Jan 15/2005				
		5	Jan 15/2005				

EFFECTIVITY: ALL
------------------



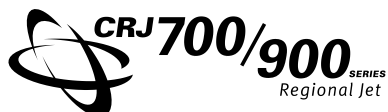

**AIRCRAFT MAINTENANCE MANUAL - PART I  
SYSTEM DESCRIPTION SECTION**

**CHAPTER 12 – SERVICING**

**TABLE OF CONTENTS**

<b>Subject</b>	<b>Ch-Se-Su</b>	<b>Effectivity</b>	<b>Page</b>
SERVICING	12-00-00		
SERVICING	A01	ALL	1
INTRODUCTION			
GENERAL DESCRIPTION			
TRAINING INFORMATION POINTS			
REPLENISHING, SYSTEMS AND COMPONENTS	12-10-00		
REPLENISHING, SYSTEMS AND COMPONENTS	A01	ALL	1
INTRODUCTION			
GENERAL			
REPLENISHING, FUEL SYSTEM	12-11-00		
REPLENISHING THE FUEL SYSTEM	A01	ALL	1
INTRODUCTION			
GENERAL DESCRIPTION			
TRAINING INFORMATION POINTS			
SERVICING, HYDRAULIC SYSTEM	12-12-00		
SERVICING THE HYDRAULIC SYSTEM	A01	ALL	1
INTRODUCTION			
GENERAL DESCRIPTION			
TRAINING INFORMATION POINTS			
REPLENISHING, OIL SYSTEM	12-13-00		
OIL SYSTEM	A01	ALL	1
INTRODUCTION			
GENERAL DESCRIPTION			
TRAINING INFORMATION POINTS			5
CREW OXYGEN SYSTEM	12-16-00		
REPLENISHING THE OXYGEN SYSTEM	A01	ALL	1
INTRODUCTION			
GENERAL DESCRIPTION			
TRAINING INFORMATION POINTS			

EFFECTIVITY: ALL
------------------

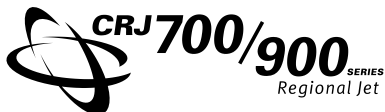

**AIRCRAFT MAINTENANCE MANUAL - PART I  
SYSTEM DESCRIPTION SECTION**

<b>Subject</b>	<b>Ch-Se-Su</b>	<b>Effectivity</b>	<b>Page</b>
REPLENISHING, WATER/WASTE SYSTEM	12-18-00		
WATER AND WASTE	A01	ALL	1
INTRODUCTION			
GENERAL DESCRIPTION			
TRAINING INFORMATION POINTS			4
SCHEDULED SERVICING	12-20-00		
SCHEDULED SERVICING	A01	ALL	1
INTRODUCTION			
GENERAL DESCRIPTION			
TRAINING INFORMATION POINTS			
SCHEDULED SERVICING	AA1	ALL	8
INTRODUCTION			
GENERAL DESCRIPTION			
TRAINING INFORMATION POINTS			
UNSCHEDULED SERVICING	12-30-00		
UNSCHEDULED SERVICING	A01	ALL	1
INTRODUCTION			
GENERAL DESCRIPTION			
TRAINING INFORMATION POINTS			

EFFECTIVITY: ALL
------------------

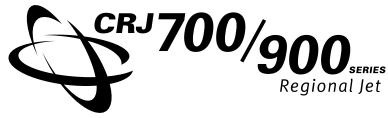

AIRCRAFT MAINTENANCE MANUAL - PART I  
SYSTEM DESCRIPTION SECTION

On A/C 10001-10999, 15001-15990

## TASK 12-00-00-001-A01 SERVICING

### INTRODUCTION

The servicing chapter contains data and procedures for the servicing tasks to be done during normal operations. This chapter is divided into the sections that follow:

- Replenishing
- Scheduled servicing
- Unscheduled servicing

### GENERAL DESCRIPTION

Figure 12-00-00-991-801.

### REPLENISHING

Replenishing the aircraft systems includes the supply of materials and fluids necessary for the correct operation of the aircraft systems. The systems that require servicing are as follows:

- Servicing the fuel system (Section 12-11-00)
- Servicing the hydraulic system (Section 12-12-00)
- Replenishing the oil systems (Section 12-13-00)
- Replenishing the oxygen system (Section 12-16-00)
- Replenishing the water/waste systems (Section 12-18-00)
- Scheduled servicing (Section 12-20-00)
- Unscheduled servicing (Section 12-30-00)

### SCHEDULED AND UNSCHEDULED SERVICING

The detailed servicing data for the scheduled and unscheduled servicing procedures are found in Part 2 chapter 12 of the Aircraft Maintenance Manual. The servicing procedures are listed the sections that follow:

- Aircraft cleaning (Section 12-21-00)
- Periodic lubrication of components (Section 12-22-00)
- Cold weather protection (Section 12-31-00)

### TRAINING INFORMATION POINTS

Only use the correct fluid that is specified for the system. Do not use mixed fluids.

When lubricating aircraft systems or components, the aircraft must be in an area free of sand, dirt and dust to prevent system contamination

Static grounding of the aircraft during servicing decreases the risk of explosions caused by electrical arcs from static electricity, lightning or stray currents.

When working with dimensions, volumes, pressures, temperature, density, etc., the interpretation of correct units is very important. Always refer to conversion tables when in doubt.

Only use calibrated test equipment and tools during maintenance.

It is recommended that a recording of serial numbers and calibration due dates of test tools and equipment be kept for reference.

EFFECTIVITY: See first page of

TASK 12-00-00-001-A01

# 12-00-00

Page 1  
Jan 15/2005

**AIRCRAFT MAINTENANCE MANUAL - PART I**  
**SYSTEM DESCRIPTION SECTION**

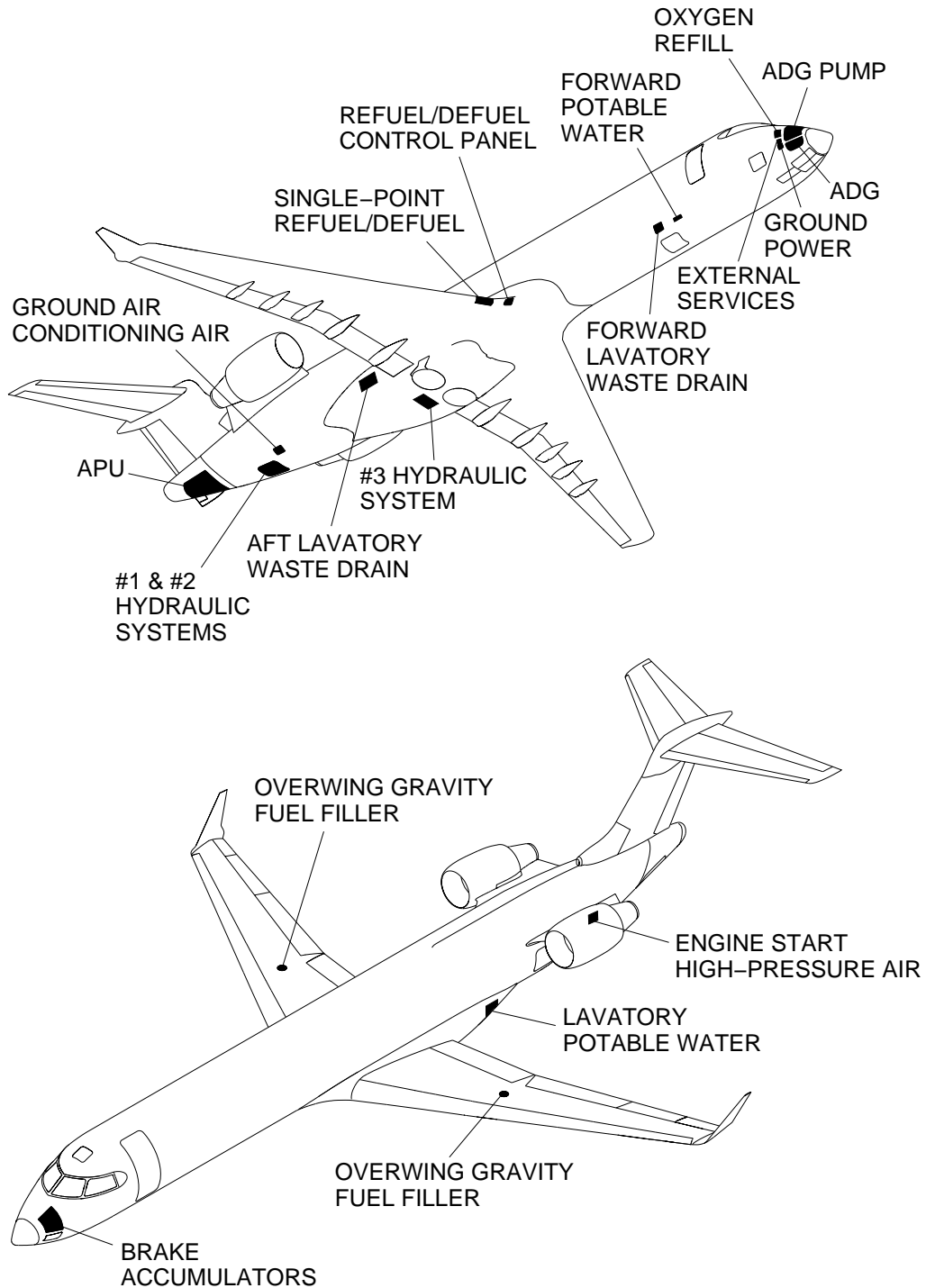

babe9a01.cgm

Servicing Panels  
 Figure 12-00-00-000001

EFFECTIVITY: See first page of

TASK 12-00-00-001-A01

**12-00-00**

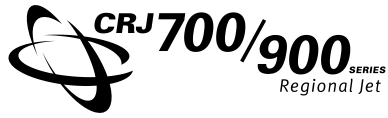

AIRCRAFT MAINTENANCE MANUAL - PART I  
SYSTEM DESCRIPTION SECTION

On A/C 10001-10999, 15001-15990

**TASK 12-10-00-001-A01  
REPLENISHING, SYSTEMS AND  
COMPONENTS**

**INTRODUCTION**

This section contains data for the servicing of the different aircraft systems that operate with liquids or gases. For detailed servicing procedures refer to part 2 of the Aircraft Maintenance Manual (AMM).

**GENERAL**

Servicing data is given for the systems that follow:

- Fuel System (Section 11-00)
- Hydraulic System (Section 12-00)
- Oil Systems (Section 13-00)
- Oxygen System (Section 16-00)
- Water and Waste System (Section 18-00)
- Scheduled Servicing (Section 20-00)
- Unscheduled Servicing (Section 30-00)

EFFECTIVITY: See first page of

TASK 12-10-00-001-A01

12-10-00

Page 1  
Jan 15/2005





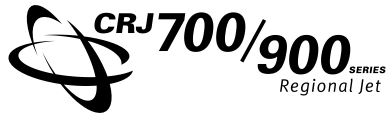

AIRCRAFT MAINTENANCE MANUAL - PART I  
SYSTEM DESCRIPTION SECTION

On A/C 10001-10999, 15001-15990

## TASK 12-11-00-001-A01 REPLENISHING THE FUEL SYSTEM

### INTRODUCTION

The servicing procedures to refuel or defuel the aircraft include pressure refueling, gravity refueling and suction defueling.

### GENERAL DESCRIPTION

Figure 12-11-00-000001.

For pressure refueling it is necessary to have a pressure source at the refuel/defuel adapter.

For suction defueling it is necessary to have a suction source at the refuel/defuel adapter.

Gravity refueling is done through two overwing gravity filler caps. Gravity refueling only fills the wing tanks. To put fuel in the center tank, fuel transfer is used.

### PRESSURE REFUELING

Pressure refueling operations are done with a pressurized fuel source connected to the refuel/defuel adapter. The refuel/defuel adapter is installed at the leading edge of the right wing root. The operator controls the refueling operation from the refuel/defuel control panel.

### SUCTION DEFUELING

Pressure defueling operations are done with a suction source connected to the refuel/defuel adapter. The refuel/defuel adapter is installed at the leading edge of the right wing root. The operator controls the defueling operation from the refuel/defuel control panel.

### GRAVITY REFUELING

The gravity refuel is accomplished through the flush overwing gravity filler caps when a pressurized refueling source is not available. There is one gravity filler cap for each wing tank. A grounding socket is provided on each wing near the filler cap for grounding the refueling nozzle.

### TRAINING INFORMATION POINTS

When refueling, make sure that the aircraft is on level ground. This will ensure that the aircraft fuel tanks accept the correct or maximum amount of fuel

Make sure that the aircraft is electrically grounded at all times when it is parked for maintenance or during bad weather. Static electrical charges in the aircraft can cause injury to persons and damage to equipment

Obey all local safety regulations and fuel safety precautions when working on the fuel system and fuel system components. Failure to obey the safety precautions can cause injury to persons and damage to equipment.

Make sure that the fuel tender, the aircraft and the fuel nozzle are grounded before refueling or defueling the aircraft. A static electrical spark during the procedure can cause an explosion or fire.

Make sure that the defuel adapter, the fuel container, and the aircraft are grounded before gravity defueling the aircraft. A static electrical spark can cause an explosion or fire.

Gravity defueling must be done in an open, well ventilated area. Fuel and fuel fumes are toxic and highly explosive. This can cause injury to person and damage to the aircraft equipment.

Obey all local safety regulations and fuel safety precautions when discarding waste fuel.

EFFECTIVITY: See first page of

TASK 12-11-00-001-A01

12-11-00

Page 1  
Jan 15/2005

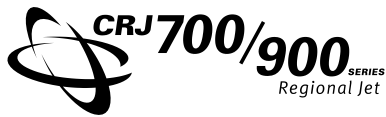

AIRCRAFT MAINTENANCE MANUAL - PART I  
SYSTEM DESCRIPTION SECTION

Waste fuel can cause contamination of the environment.

Ensure the overwing filler caps are chained to the wing. This is to prevent an unsecured filler cap from flying off.

Draining water contamination from the bottom of the fuel tanks must be done before flight. This will make sure that the engines operate correctly and can also prevent corrosion of the fuel system components.

Use of fungicide additives are highly recommended. The additives are used to sterilize and to keep the fuel system free of fungus and/or microbial life.

Before refueling, the wheel chocks should be moved a short distance away from the tires. This is done to prevent the chocks from being caught when the tires spread out with the additional fuel weight.

EFFECTIVITY: See first page of

TASK 12-11-00-001-A01

12-11-00

Page 2  
Jan 15/2005

AIRCRAFT MAINTENANCE MANUAL - PART I  
SYSTEM DESCRIPTION SECTION

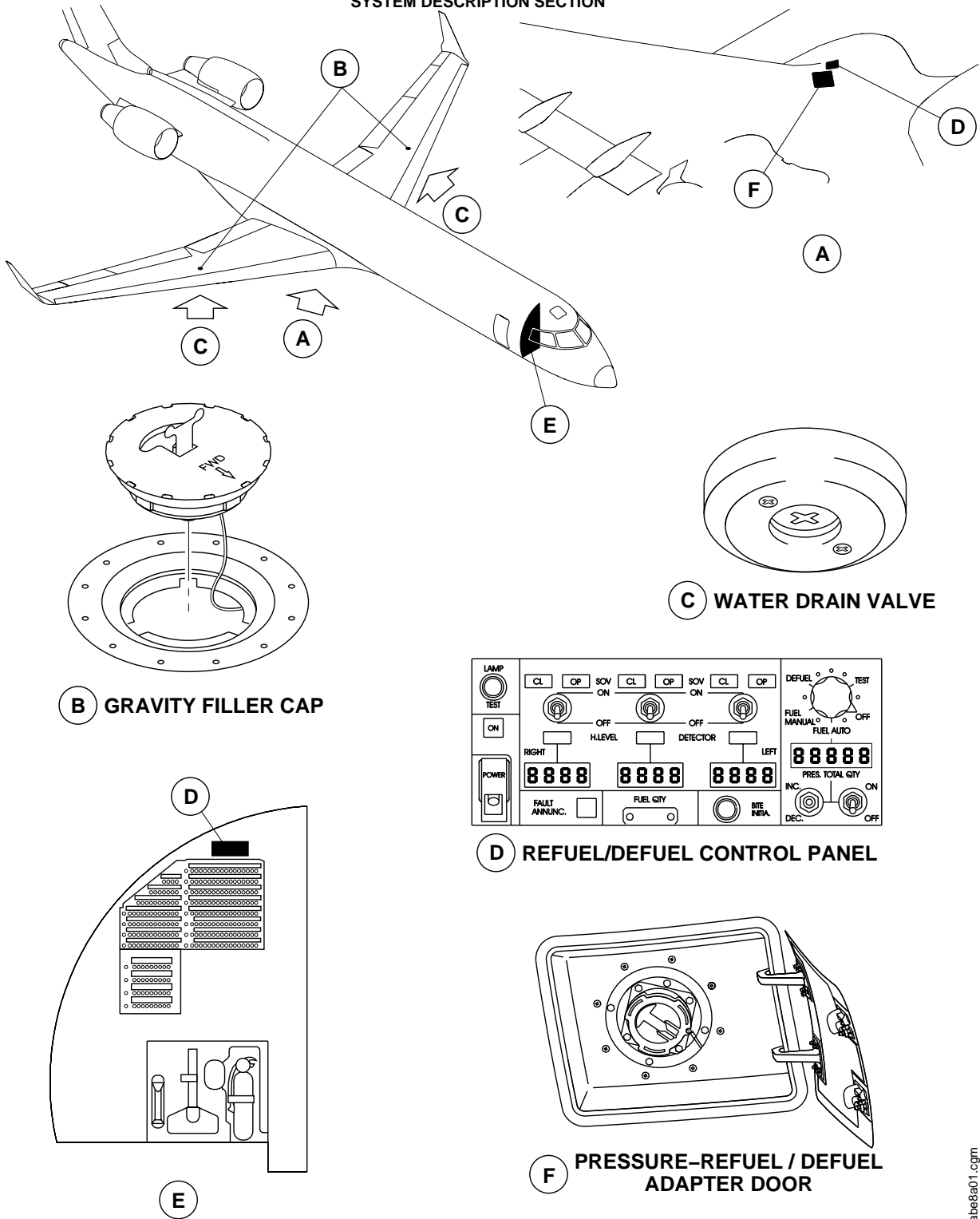

Refueling Points and Drains  
Figure 12-11-00-000001

EFFECTIVITY: See first page of

TASK 12-11-00-001-A01

12-11-00

Page 3  
Jan 15/2005



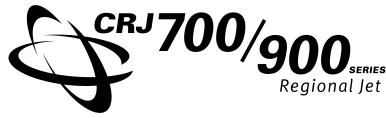

AIRCRAFT MAINTENANCE MANUAL - PART I  
SYSTEM DESCRIPTION SECTION

On A/C 10001-10999, 15001-15990

## TASK 12-12-00-001-A01 SERVICING THE HYDRAULIC SYSTEM

### INTRODUCTION

Replenishment of the hydraulic systems includes the procedures to do quantity checks and to add fluid and/or compressed gas to the systems. The hydraulic systems use a phosphate ester-based hydraulic fluid and nitrogen gas.

### GENERAL DESCRIPTION

The aircraft hydraulic systems supply fluid and power to many aircraft components for system operation and control. The hydraulic fluid and compressed gas in the landing gear shock struts absorb the shock during landing. The systems and components that require hydraulic servicing are as follows:

- Hydraulic systems no. 1, 2, and 3.
- Landing gear shock struts
- Air driven generator (ADG)

### REPLENISHING THE HYDRAULIC SYSTEMS

Figure 12-12-00-000001.

Three bootstrap-type hydraulic reservoirs supply fluid to the systems. Each of the reservoir bootstrap chamber is pressurized to prevent pump cavitation during start-up.

Each reservoir has a quantity indicator that reads from 0 to 100 percent. In the flight compartment, hydraulic fluid quantity can be checked on the EICAS "HYDRAULIC" synoptic page.

The components and servicing points for systems no. 1 and 2 are located in the aft equipment compartment. The components for

system no. 3 are in the aft wing box structure. The servicing point for no. 3 hydraulic system is at the right rear wing root.

### REPLENISHING THE LANDING GEAR

The landing gear shock struts are filled with a mineral-based hydraulic fluid. The shock struts are charged with compressed nitrogen. A placard on each shock strut provides data for servicing.

The main landing gear uses hydraulic fluid and compressed nitrogen in the same chamber to act as a shock absorber. Fluid and compressed nitrogen are forced through a calibrated orifice controlled by a metering pin. This restriction in fluid transfer absorbs the loads imposed on the landing gear during landing.

The nose landing gear hydraulic fluid and compressed nitrogen are contained in individual chambers, separated by a floating piston. The movement of the piston compressing the nitrogen absorbs the loads imposed on the landing gear during landing.

### REPLENISHING THE AIR DRIVEN GENERATOR (ADG)

Figure 12-12-00-000002.

The ADG has a separate hydraulic system that is used to retract the ADG after it has been deployed. The retraction system consists of a reservoir and hand pump that is filled with mineral-based hydraulic fluid.

### TRAINING INFORMATION POINTS

Before starting work on the ADG, make sure that all applicable safety precautions have been reviewed and understood.

Safety precaution must be used when working around highly toxic phosphate ester-based hydraulic fluids.

EFFECTIVITY: See first page of

TASK 12-12-00-001-A01

12-12-00

Page 1  
Jan 15/2005

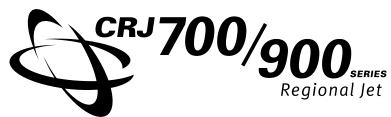

**AIRCRAFT MAINTENANCE MANUAL - PART I**  
**SYSTEM DESCRIPTION SECTION**

Obey all operator policies and local regulations  
when discarding waste/drained hydraulic fluid.

EFFECTIVITY: See first page of

TASK 12-12-00-001-A01

**12-12-00**

Page 2  
Jan 15/2005

**AIRCRAFT MAINTENANCE MANUAL - PART I**  
**SYSTEM DESCRIPTION SECTION**

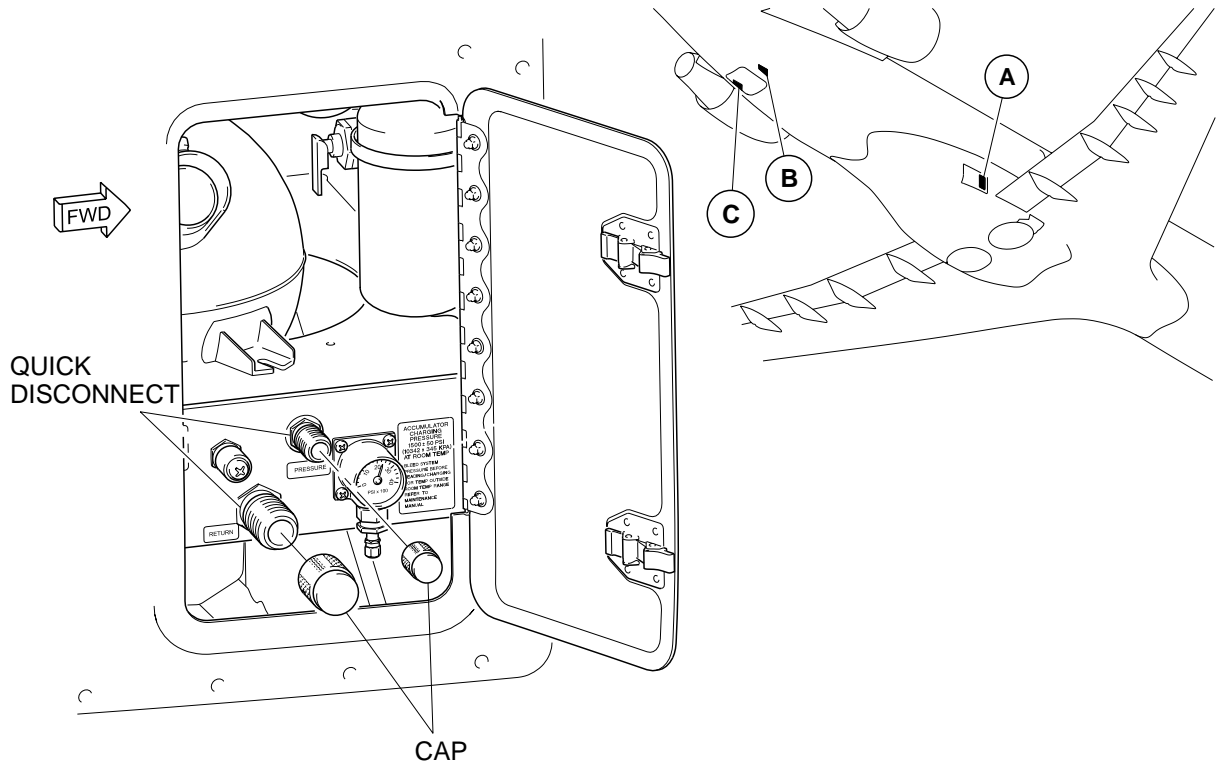

**A NO. 3 HYDRAULIC SYSTEM SERVICE PANEL**

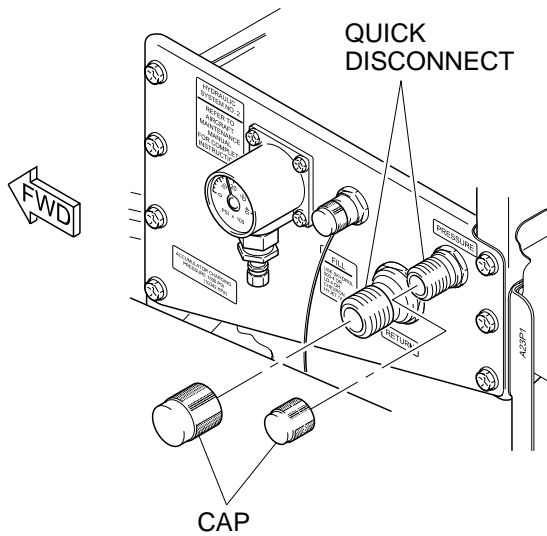

**B NO. 2 HYDRAULIC SYSTEM SERVICE PANEL**

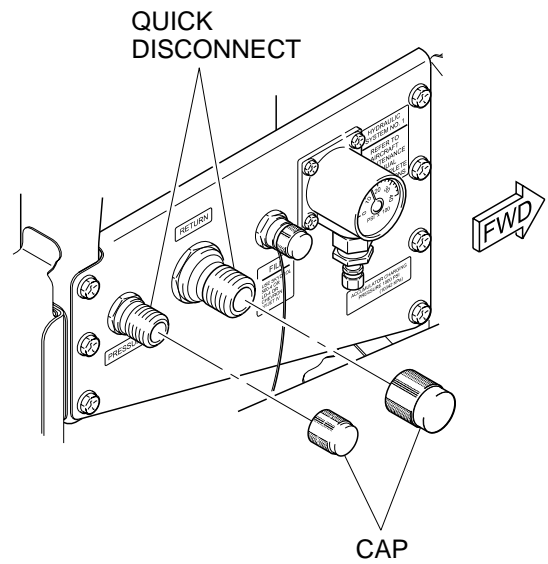

**C NO. 1 HYDRAULIC SYSTEM SERVICE PANEL**

Replenishing the Hydraulic System  
 Figure 12-12-00-000001

EFFECTIVITY: See first page of

TASK 12-12-00-001-A01

**12-12-00**

Page 3  
 Jan 15/2005

**AIRCRAFT MAINTENANCE MANUAL - PART I**  
**SYSTEM DESCRIPTION SECTION**

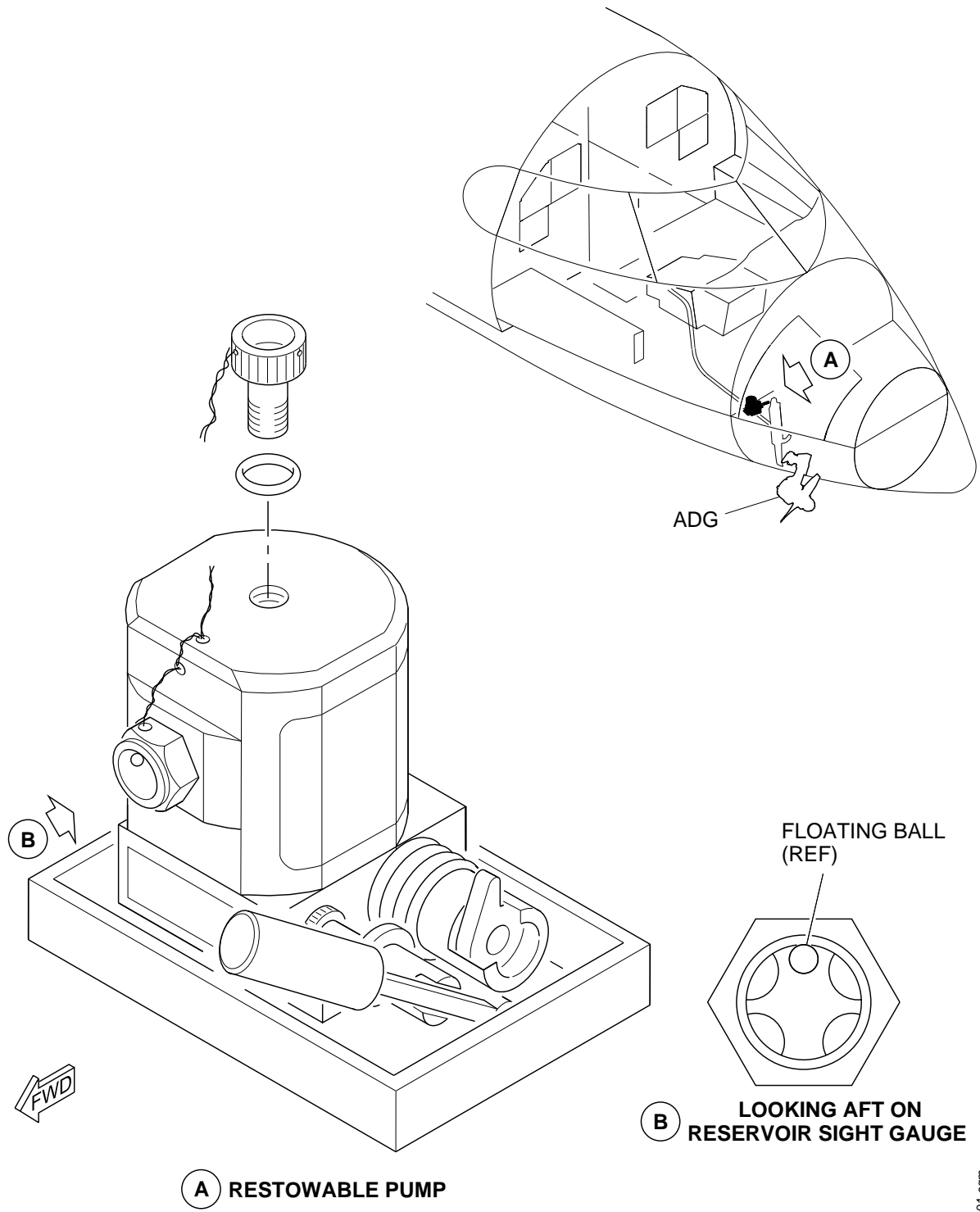

bab6a01.cgm

Servicing - ADG  
 Figure 12-12-00-000002

EFFECTIVITY: See first page of

TASK 12-12-00-001-A01



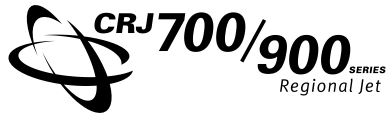

AIRCRAFT MAINTENANCE MANUAL - PART I  
SYSTEM DESCRIPTION SECTION

On A/C 10001-10999, 15001-15990

## TASK 12-13-00-001-A01 OIL SYSTEM

### INTRODUCTION

The function of the oil system is to provide lubrication and cooling to the engine bearings and gears. Servicing of the oil system includes the procedures for quantity checks, draining, and to adding oil to the components that follow:

- Engine oil tanks
- Airframe mounted engine oil tank
- Auxiliary power unit (APU)
- Air turbine starter (ATS)

### GENERAL DESCRIPTION

Figures 12-13-00-000001  
and 12-13-00-000003.

### ENGINE OIL TANKS

Each engine is lubricated with oil contained in an external engine oil tank. Access to the oil tank is gained by opening the engine nacelles and core cowls. The engine oil supply can be manually replenished at the engine, or through an optional remote replenishment system in the aft equipment compartment.

The servicing components for the engine oil system include the components that follow:

- Oil quantity sight gauge
- Oil quantity transmitter
- Oil tank
- Gravity fill port
- Remote filling system (optional)

When the oil level is low, oil is added directly to the oil tank. Oil is drained from the tank when the level is too high or for maintenance

servicing. The oil tank level indicator is provided near the upper gravity fill adapter. It has a power ON switch and a FULL indicator light. Engine oil quantity indication is also provided on the EICAS MENU page. The gravity filler port has a removable cap which is removed when it is necessary to add oil to the tank manually. Oil can also be added to the oil tank through the remove fill connection.

### AIRFRAME MOUNTED OIL TANK (OPTIONAL)

The optional, airframe mounted, remote oil tank is installed in the aft equipment compartment. The system allows maintenance personnel to fill the left and right engine oil tanks using oil from the remote tank. The system is controlled from the remote engine oil servicing panel in the aft equipment compartment. The servicing components for the remote replenishment system include:

- Oil replenishment tank
- Quantity sight gauge
- Selector valve
- Control panel
- Oil replenishment pump

A 28 Vdc electric pump supplies the engines with oil from the replenishment tank. The supply pump is controlled from the control panel. Oil quantity indications of the engine oil tanks are supplied with the signal conditioner unit.

The control panel has the switch/lights that follow:

- "ON"PTT/POWER switch/light
- LH/RH FILL switch/light
- LH/RH 100% switch/light

On the control panel, push and hold the "ON"PTT/POWER switch/light and make sure that all three switch/lights illuminate. Release

EFFECTIVITY: See first page of

TASK 12-13-00-001-A01

# 12-13-00

Page 1  
Jan 15/2005

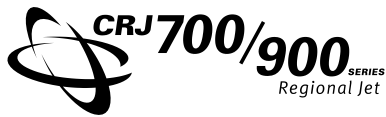

**AIRCRAFT MAINTENANCE MANUAL - PART I  
SYSTEM DESCRIPTION SECTION**

the PTT/POWER switch/light and make sure that the "ON" switch/light stays on and that the LH/RH FILL and LH/RH 100% switch/lights go out.

**NOTE**

When the PTT/POWER is pushed and released, electrical power to the replenishment pump will only be available for 10 minutes.

To service an engine oil system, move the spring-loaded selector valve from the OFF position and hold it to the applicable LH or RH position. Make sure that the respective LH or RH FILL switch/light comes on. Continue to hold the selector valve until the respective 100% switch/light comes on. At the same time the respective FILL switch/light will go out and the pump will stop. Release the selector valve to the OFF position.

Servicing of the remote replenishment oil tank is completed by the maintenance crew. To add oil, the filler cap is removed and the necessary quantity of oil is added as shown by a sight gauge. Oil is drained from the tank using the drain valve on the bottom of the tank.

EFFECTIVITY: See first page of

TASK 12-13-00-001-A01

**12-13-00**

Page 2  
Jan 15/2005

**AIRCRAFT MAINTENANCE MANUAL - PART I**  
**SYSTEM DESCRIPTION SECTION**

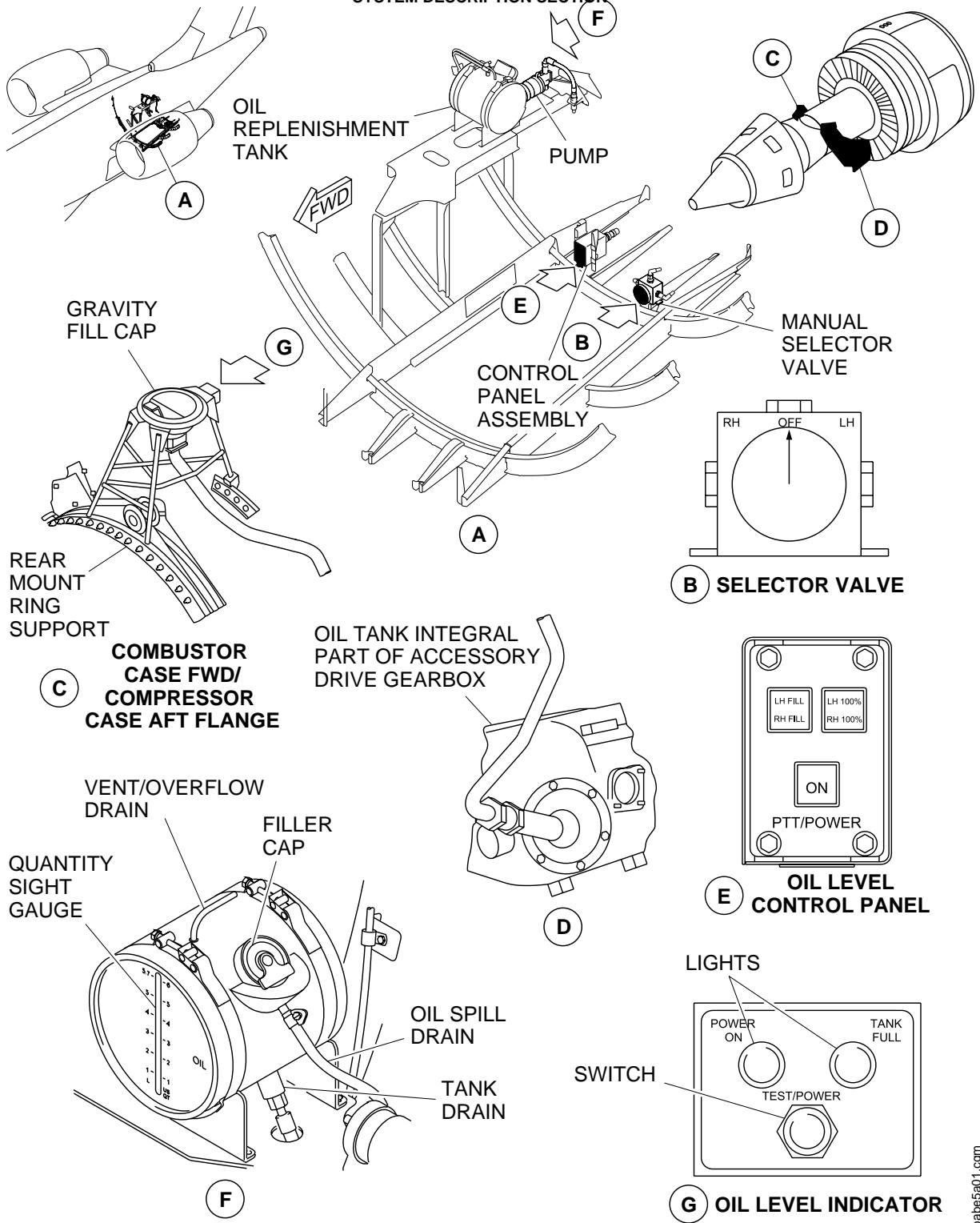

babe5a01.cgm

Engine and Remote Oil Servicing  
 Figure 12-13-00-000001

EFFECTIVITY: See first page of  
 TASK 12-13-00-001-A01

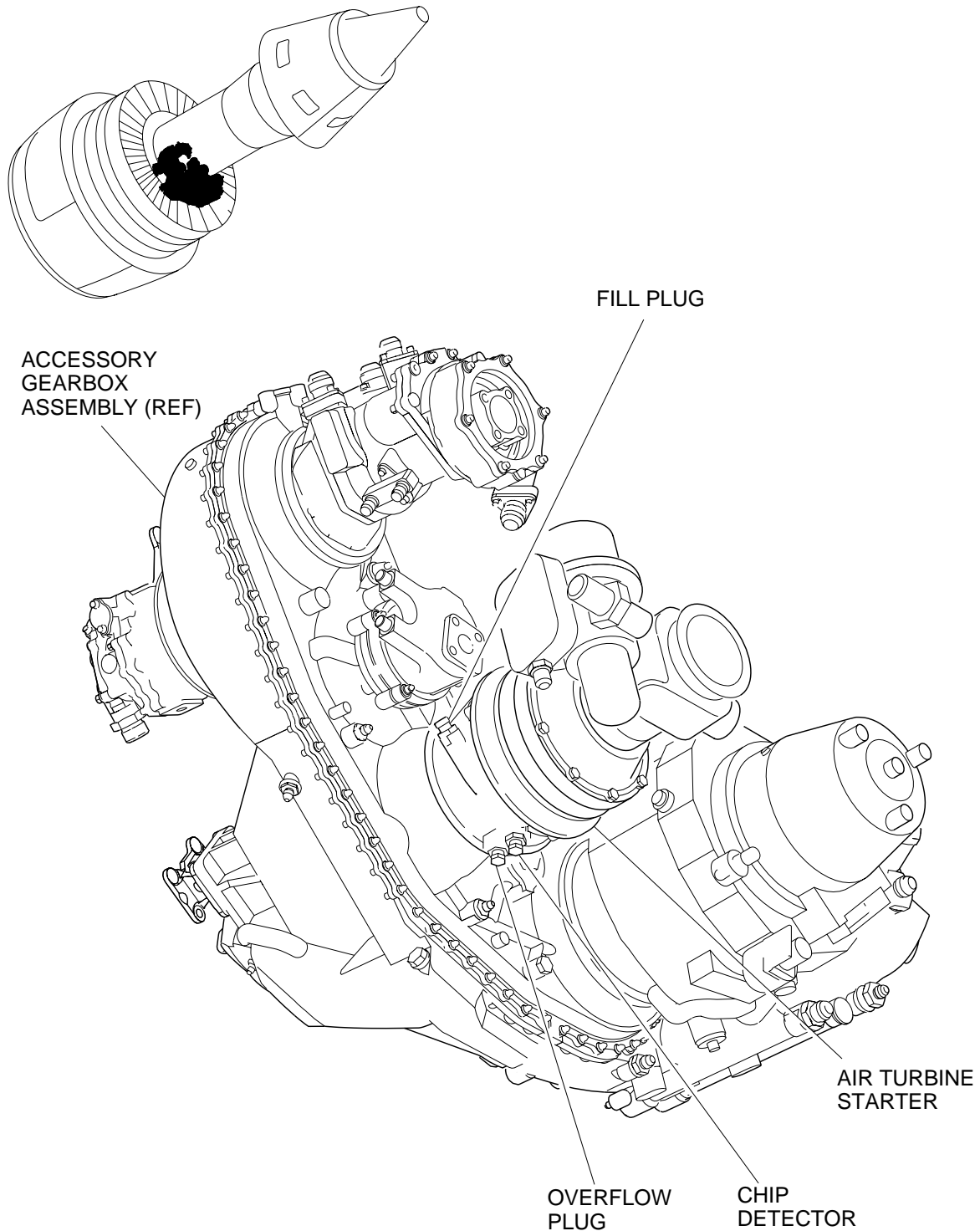

Air Turbine Starter Oil - Servicing  
Figure 12-13-00-000003

bask8a01.cgm

EFFECTIVITY: See first page of

TASK 12-13-00-001-A01

**12-13-00**

Page 4  
Jan 15/2005

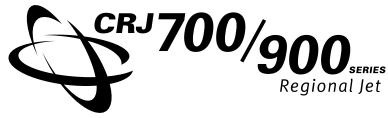

AIRCRAFT MAINTENANCE MANUAL - PART I  
SYSTEM DESCRIPTION SECTION

## AUXILIARY POWER UNIT (APU)

Figure 12-13-00-000002.

The APU is installed in a closed area in the tail cone of the aircraft. Servicing of the APU oil system is done manually.

The oil level is examined through the gravity filler port found on the left side of the APU. The filler port has a cap which is removed when it is necessary to add oil to the APU oil tank. Oil must be manually added until it reaches the top edge of the cap. Oil is drained from the oil tank by removing the drain plug at the bottom of the APU oil tank.

## AIR TURBINE STARTER (ATS)

There are two ATS units installed on the aircraft, one mounted on each engine. When servicing is necessary, the cowl doors for the engine are opened to gain access to the ATS.

The servicing components for the ATS oil system include the components that follow:

- Filler port
- Magnetic drain plug

To fill the ATS reservoir, the cap is first removed and oil is then added to the oil tank directly through the filler port. When the oil is at the bottom of the filler port threads, the oil level is correct. If too much oil is added, it comes out of the filler port.

To drain the ATS reservoir, the drain plug is removed and the oil is permitted to flow out of the ATS oil tank. When the necessary quantity of oil is drained, the drain plug is installed.

## TRAINING INFORMATION POINTS

Before examining the ADG oil level, make sure that the aircraft is parked on level ground.

EFFECTIVITY: See first page of

TASK 12-13-00-001-A01

12-13-00

Page 5  
Jan 15/2005

**AIRCRAFT MAINTENANCE MANUAL - PART I  
SYSTEM DESCRIPTION SECTION**

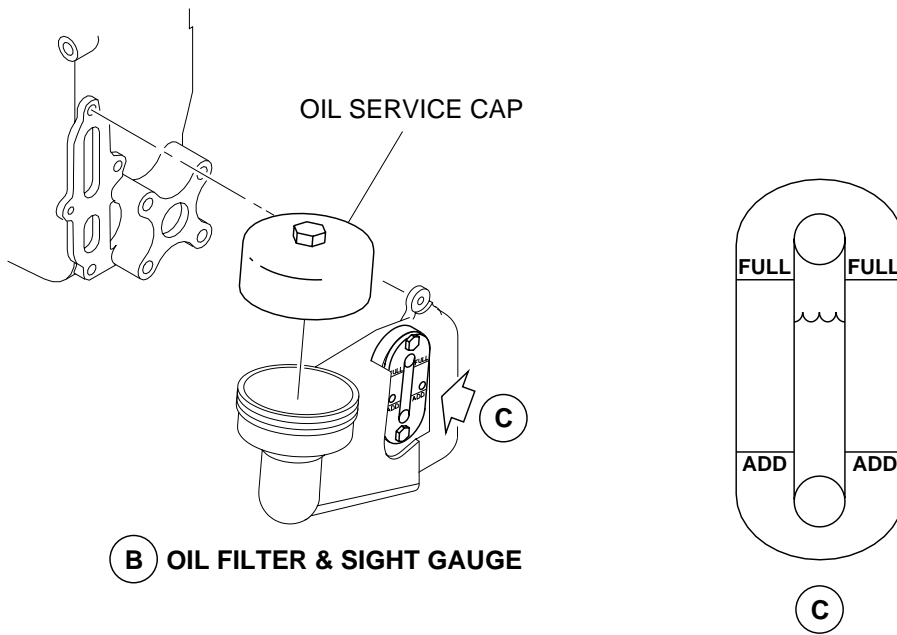
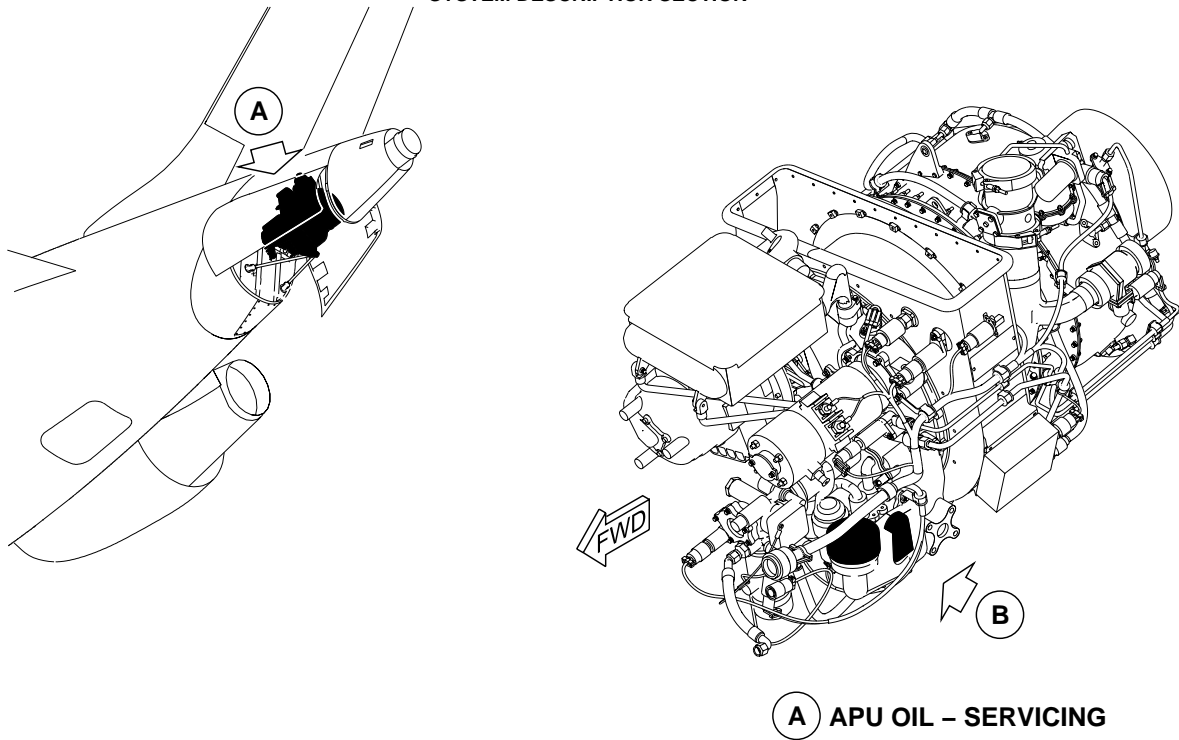

APU Oil Servicing  
Figure 12-13-00-000002

babe4a01.cgm

EFFECTIVITY: See first page of

TASK 12-13-00-001-A01

**12-13-00**

Page 6  
Jan 15/2005

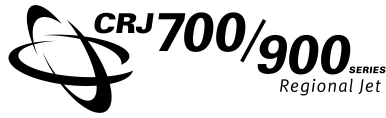

AIRCRAFT MAINTENANCE MANUAL - PART I  
SYSTEM DESCRIPTION SECTION

On A/C 10001-10999, 15001-15990

## TASK 12-16-00-001-A01 REPLENISHING THE OXYGEN SYSTEM

### INTRODUCTION

Replenishing of the oxygen system is through the oxygen ground servicing panel located on the right side of the forward fuselage.

### GENERAL DESCRIPTION

Figure 12-16-00-000001.

The oxygen replenishment system has the components that follow:

- Oxygen storage cylinder and regulator assembly
- Oxygen ground servicing panel pressure gauge
- Oxygen filler valve
- Oxygen pressure transducer

### OXYGEN STORAGE CYLINDERS AND REGULATOR ASSEMBLY

The oxygen storage cylinders and regulator assemblies are located in an enclosure to the rear of the crew wardrobe.

### OXYGEN GROUND SERVICING PANEL PRESSURE GAUGE

The oxygen ground servicing panel pressure gauge is installed on the oxygen ground servicing panel. It is mechanical and indicates the total oxygen pressure in the cylinders. This gauge has a range of 0 to 2000 psi, in 100 psi increments.

### OXYGEN FILLER VALVE

The oxygen filler valve is used by the ground crew to fill the oxygen storage cylinders.

### OXYGEN PRESSURE TRANSDUCER

The EICAS STATUS page shows the total oxygen pressure in the oxygen storage cylinders. The oxygen pressure transducer is a sealed unit that has provisions to compensate for temperature changes. The transducer sends electrical signals to the engine indication and crew alerting system (EICAS).

The temperature correction chart must be used when servicing the oxygen system. This is done by comparing the oxygen pressure indication on the EICAS STATUS page with the pressure indication given by the ground servicing panel pressure gauge.

### TRAINING INFORMATION POINTS

Use the pressure versus temperature correction chart when filling the oxygen system.

Ensure dirt, oil, grease or solvents do not get on hands, clothing, system components or on equipment in service. These substances can burn or explode on contact with pressurized oxygen.

EFFECTIVITY: See first page of

TASK 12-16-00-001-A01

12-16-00

Page 1  
Jan 15/2005

**AIRCRAFT MAINTENANCE MANUAL - PART I**  
**SYSTEM DESCRIPTION SECTION**

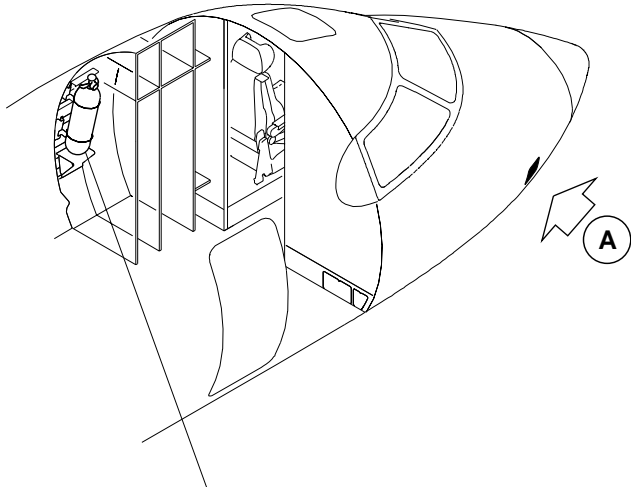

**CREW OXYGEN BOTTLE**

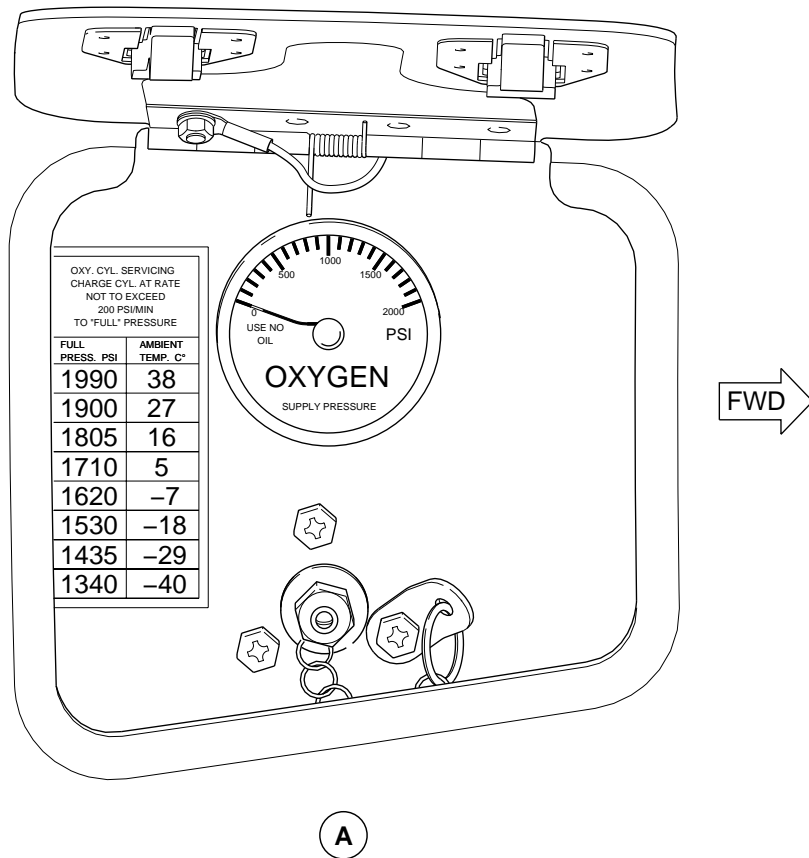

**Replenishing the Oxygen System**  
**Figure 12-16-00-000001**

babs3a01.cgm

EFFECTIVITY: See first page of

TASK 12-16-00-001-A01

**12-16-00**

Page 2  
 Jan 15/2005



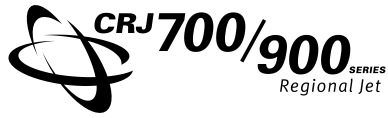

AIRCRAFT MAINTENANCE MANUAL - PART I  
SYSTEM DESCRIPTION SECTION

On A/C 10001-10999, 15001-15990

## **TASK 12-18-00-001-A01 WATER AND WASTE**

### **INTRODUCTION**

The potable/wash water system stores and supplies heated and pressurized water to the galleys and lavatories. A drain system removes waste water from the sinks. The aircraft also has provisions for storing, flushing and removing lavatory waste.

### **GENERAL DESCRIPTION**

Figures 12-18-00-000001  
and 12-18-00-000002.

### **POTABLE/WASH WATER SYSTEM**

The potable/wash water system stores, supplies and controls the flow of water to the galleys and lavatories. The water/waste replenishing system includes procedures for quantity checks, draining, flushing and filling the lavatory waste water system.

### **POTABLE/WASH WATER SYSTEM REPLENISHING**

The aft potable/wash water has a 10.1 U.S. gallon tank that is replenished through an exterior service panel. The service panel is located on the left side of fuselage, aft of the wing. The forward potable/wash water has a 11.5 U.S. gallon tank. The service panel is located on right lower side of forward fuselage. The service panels include the components that follow:

- Water fill connection
- Tank overflow outlet
- Tank drain/fill handle
- Tank full/empty level indicator lights

To fill the water tank, the operator connects a water pressure source to the water fill port, then the fill and drain T—handle is turned to the right which opens the fill valve. When the tank is FULL water will flow out through the overflow drain. The water quantity is also checked using the FULL/EMPTY water level lights on the potable water control panel in the galley

When the fill/drain T-handle is turned to the left it operates a drain valve on the bottom of the water tank.

EFFECTIVITY: See first page of

TASK 12-18-00-001-A01

12-18-00

Page 1  
Jan 15/2005

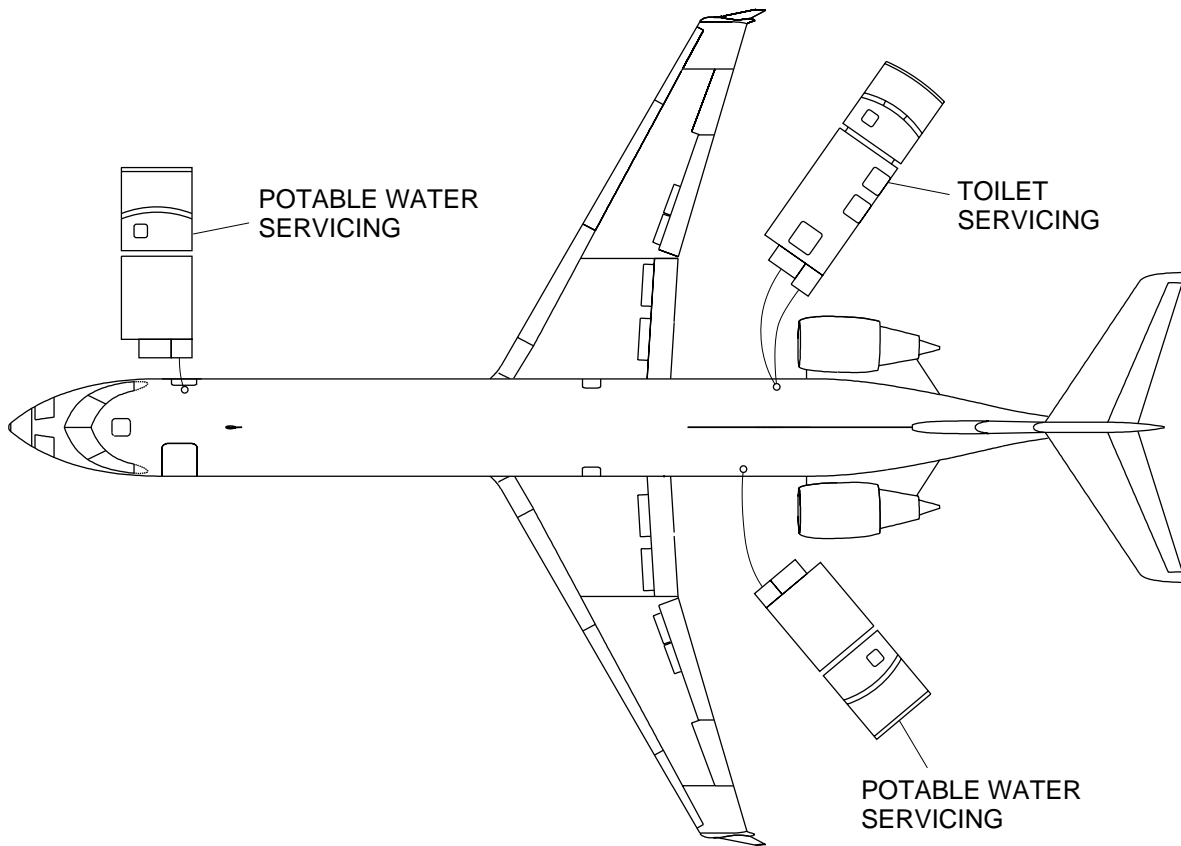

babe2a01.cgm

Water and Waste Servicing  
Figure 12-18-00-000001

EFFECTIVITY: See first page of

TASK 12-18-00-001-A01

**12-18-00**

Page 2  
Jan 15/2005

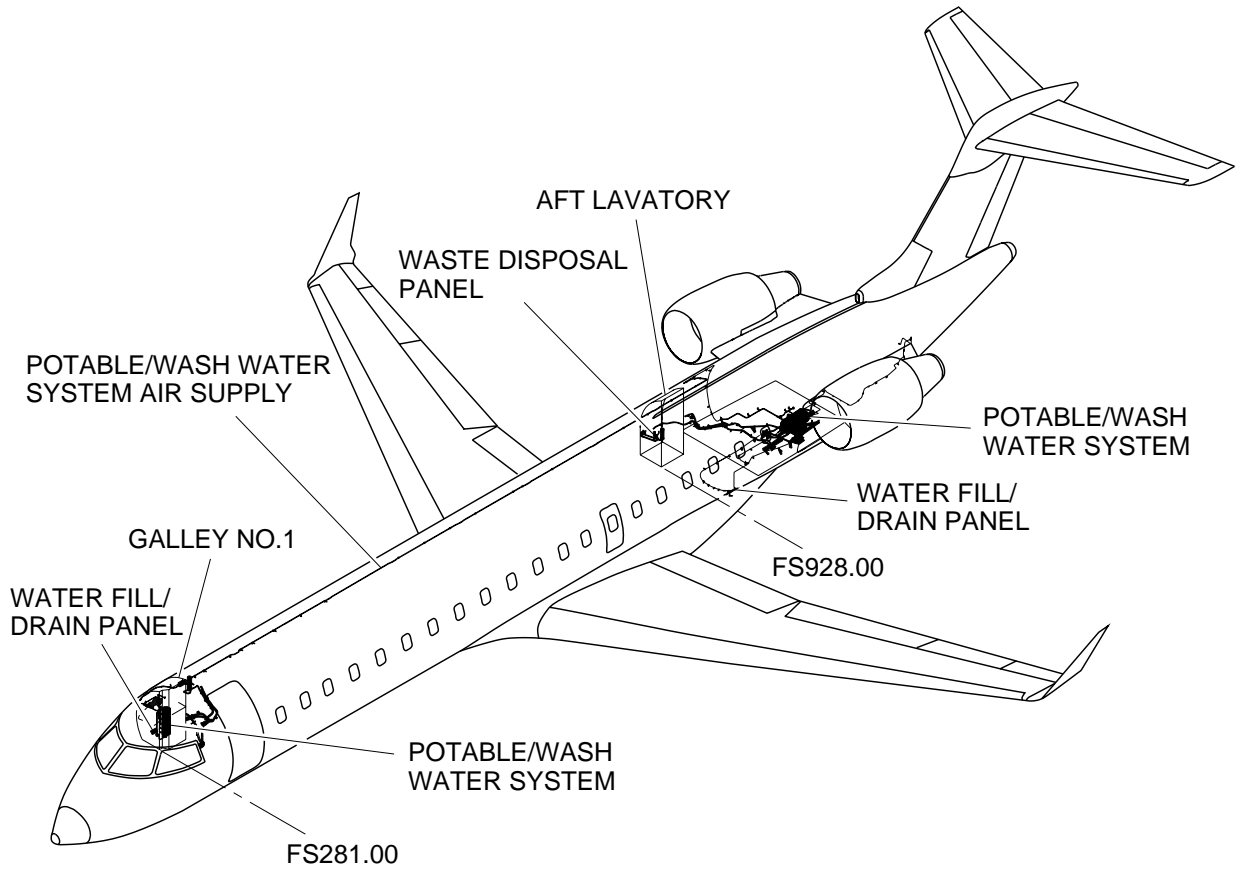

babe1a01.cgm

Water and Waste System  
Figure 12-18-00-000002

EFFECTIVITY: See first page of

TASK 12-18-00-001-A01

12-18-00

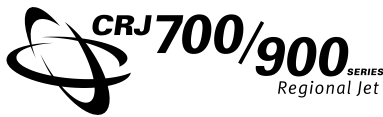

AIRCRAFT MAINTENANCE MANUAL - PART I  
SYSTEM DESCRIPTION SECTION

## WASTE WATER SYSTEM REPLENISHING

The filling and draining instructions are located on the back of the service panel and in part 2 of the AMM.

Figure 12-18-00-000003.

The lavatory waste water system is replenished through a service panel at the right wing aft root fairing. The service panel includes a waste outlet, a recharge port, a waste tank drain handle and a waste container full indicator light. The service panel has a hinged cover that latches closed. The cover is opened to connect the external waste drain line from a lavatory servicing cart to the waste outlet.

When the waste tank drain T-handle is pulled and turned left, it operates a drain valve on the bottom of the lavatory waste tank. When the valve is opened, the contents of the waste tank flow under gravity, out of the waste outlet into the external drain line of the servicing cart.

Upon draining the waste, the recharging line from the servicing cart is connected to the recharge port. The waste tank is then flushed and filled with a fresh quantity of chemical solution. The T-handle must be turned toward the right and pushed in to close the drain for filling.

### NOTE

THE T-HANDLE MUST BE IN THE  
CLOSED AND LOCKED POSITION  
BEFORE THE LAVATORY SERVICE  
PANEL CAN BE CLOSED.

### TRAINING INFORMATION POINTS

Make sure all service panel ports are closed tight. Leaking fluids will turn to ice up at high altitudes and may form large masses, which can break off and cause damage to aircraft.

Make sure there is flushing solution in the tank before using the flush switch. This can cause the pump to run dry and overheat.

When the aircraft is parked overnight in very cold weather, all the water and lavatory fluid must be drained to prevent freezing.

EFFECTIVITY: See first page of

TASK 12-18-00-001-A01

12-18-00

Page 4  
Jan 15/2005

**AIRCRAFT MAINTENANCE MANUAL - PART I**  
**SYSTEM DESCRIPTION SECTION**

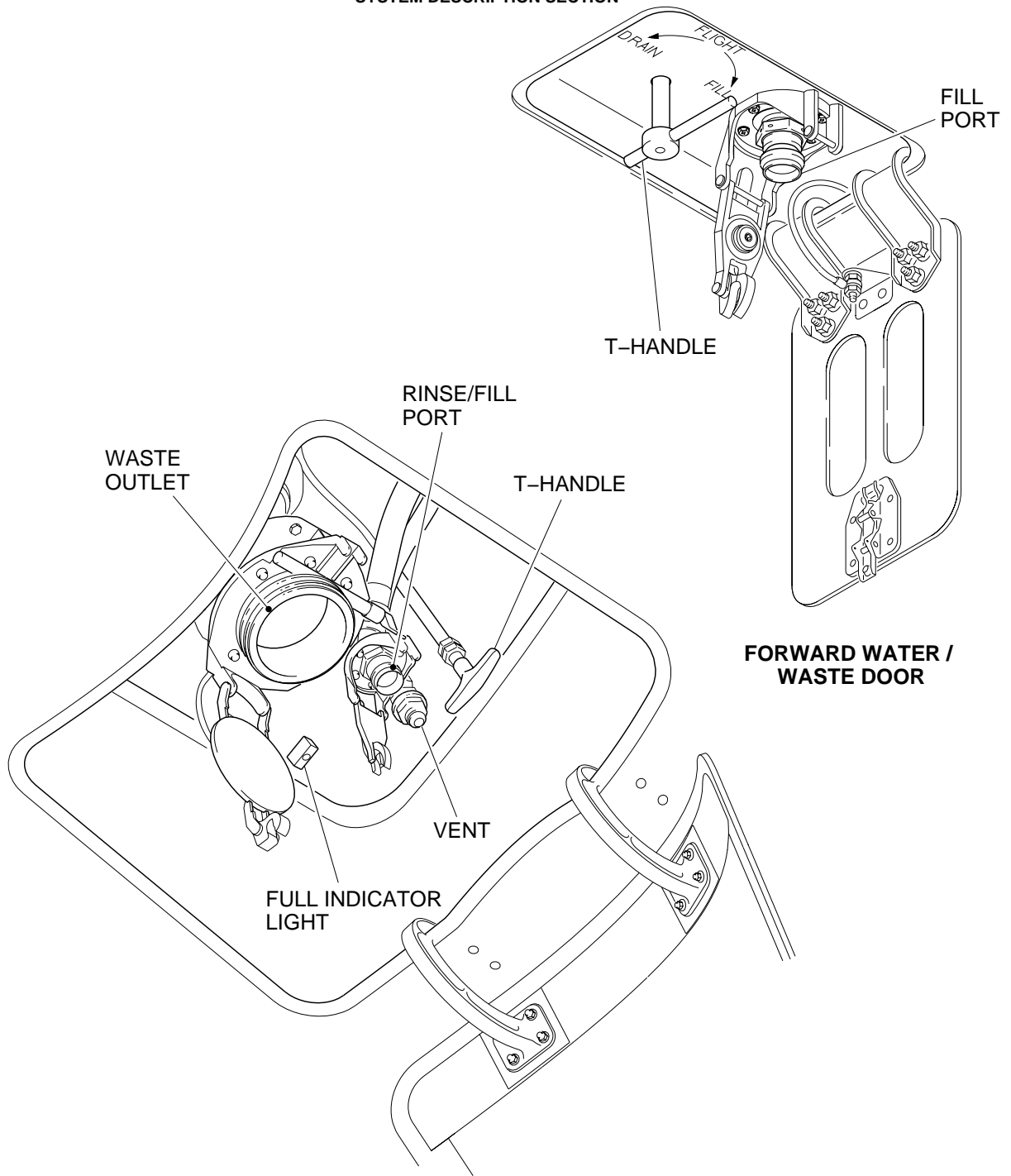

**WASTE DISPOSAL SYSTEM**  
**SERVICE PANEL**

Water and Waste Servicing System  
 Figure 12-18-00-000003

bab09a01.cgm

EFFECTIVITY: See first page of  
 TASK 12-18-00-001-A01



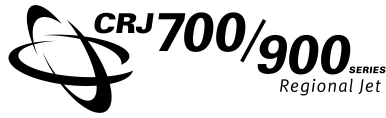

AIRCRAFT MAINTENANCE MANUAL - PART I  
SYSTEM DESCRIPTION SECTION

On A/C 10001-10999

## TASK 12-20-00-001-A01 SCHEDULED SERVICING

### INTRODUCTION

Scheduled servicing procedures include those tasks included in the preventive maintenance schedule of the aircraft. Generally, these are the minimum standards established to make the aircraft airworthy. Operators can use higher approved standards to suit individual operations.

### GENERAL DESCRIPTION

Figures 12-20-00-000001, 12-20-00-000002, 12-20-00-000003, 12-20-00-000004 and 12-20-00-000005.

Scheduled servicing procedures include:

- Aircraft cleaning
- Lubrication

### AIRCRAFT CLEANING

The exterior of the aircraft must be washed and polished to prevent deterioration of the painted surfaces and corrosion of the polished surfaces. The interior surfaces, carpets and furnishings must also be cleaned frequently.

Areas that require attention during cleaning are:

- Floor coverings
- Toilet enclosure
- Aircraft exterior
- Aircraft internal surfaces and furnishings
- Windshields
- Side windows
- Passenger windows
- Navigation lights

- Anticollision lights
- Landing/taxi light covers

### LUBRICATION

Mechanical components require regular lubrication to make sure they operation correctly and to prevent corrosion. Lubricants that are used include grease, aerosol lubricants, dry lubricant and silicone compounds. Lubricants may be applied by grease gun, oil can, aerosol spray, brush or by hand.

Aircraft areas that require regular lubrication include:

- Nose landing gear
- Nose landing gear doors
- Main landing gear
- Main landing gear doors
- Overwing emergency exits
- Baggage compartment door
- Passenger door
- Horizontal stabilizer trim actuator
- Flap and slat components
- Air-driven generator

### TRAINING INFORMATION POINTS

Before starting a task, make sure that all safety precautions are read and understood.

Always use approved window cleaning solutions and procedures.

Before applying lubricants, make sure that the surface area is free of all dirt and moisture.

Only use approved materials for servicing.

Remove unwanted lubricants after servicing.

EFFECTIVITY: See first page of

TASK 12-20-00-001-A01

12-20-00

Page 1  
Jan 15/2005

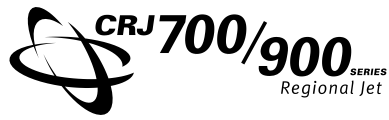

AIRCRAFT MAINTENANCE MANUAL - PART I  
SYSTEM DESCRIPTION SECTION

Do a leak check if any fluid lines are replaced  
or disturbed.

EFFECTIVITY: See first page of

TASK 12-20-00-001-A01

12-20-00

Page 2  
Jan 15/2005



**AIRCRAFT MAINTENANCE MANUAL - PART I**  
**SYSTEM DESCRIPTION SECTION**

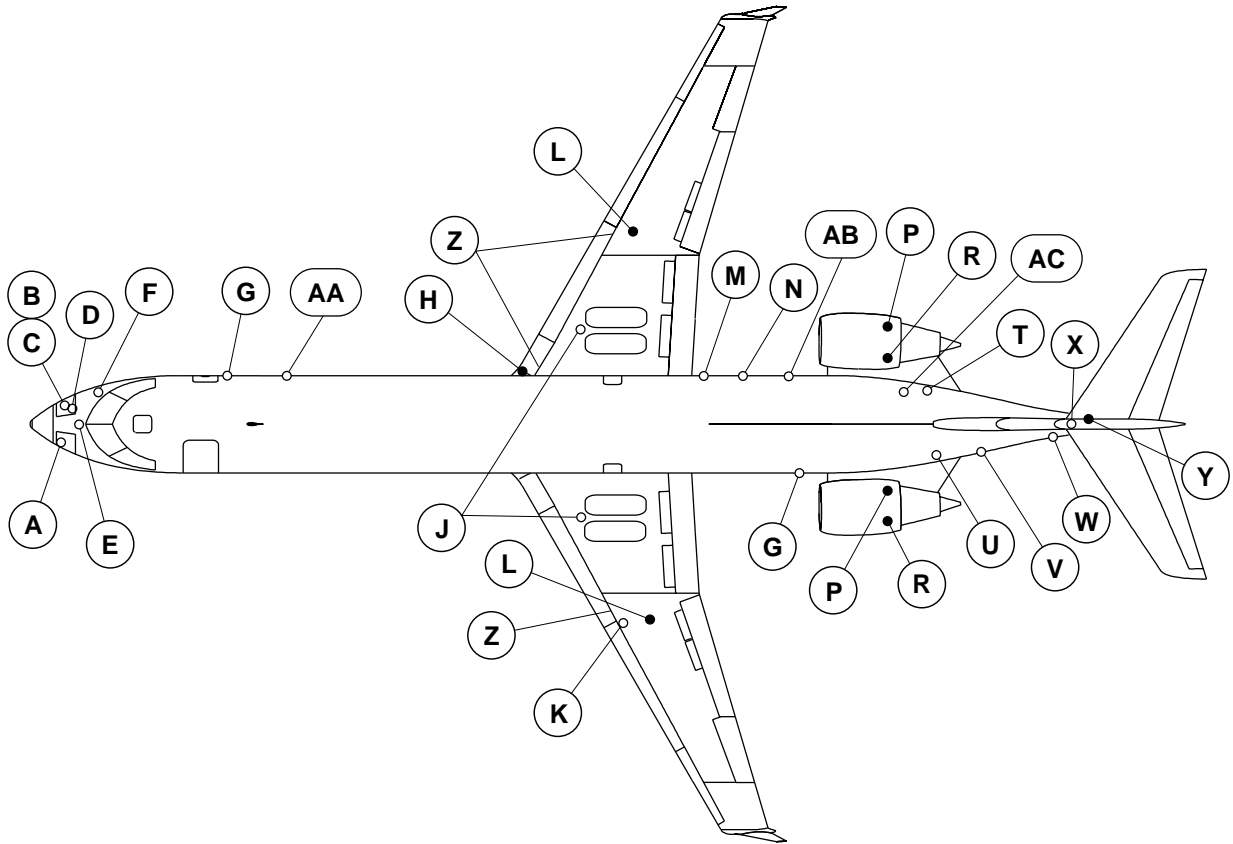

**LEGEND**

- Located on the lower side.
- Located on the upper side.
- A. Brake acc. charge.
- B. AC external power.
- C. Ground crew service panel with interphone.
- D. ADG oil servicing.
- E. NLG tire/oleo servicing/lubrication.
- F. Oxygen system charging valve & gauge.
- G. Potable Water servicing.
- H. Press. refuel/defuel panel & adapter.
- J. MLG tire/oleo servicing/lubrication.
- K. Fuel tank water drain (typical).
- L. Overwing gravity fuel filler.
- M. No. 3 hyd. sys. acc. charging pt., press. gauge & reservoir filler conn..
- N. AFT toilet servicing.
- P. Engine oil storage tank.
- R. IDG oil servicing.
- T. No. 2 hydraulic system accumulator / fill point.
- U. No. 1 hydraulic system accumulator & rear interphone / fill point.
- V. H.P. ground air servicing.
- W. APU servicing.
- X. Tail bumper servicing.
- Y. Horizontal stab. trim actuator oil servicing.
- Z. Wing grounding points.
- AA. Forward toilet servicing (optional).
- AB. L.P. air conditioning connection.
- AC. Single point oil replenishment system.

babd8a01.cgm

Aircraft Servicing - Locations  
 Figure 12-20-00-000001

EFFECTIVITY: See first page of

TASK 12-20-00-001-A01

**12-20-00**

**AIRCRAFT MAINTENANCE MANUAL - PART I  
SYSTEM DESCRIPTION SECTION**

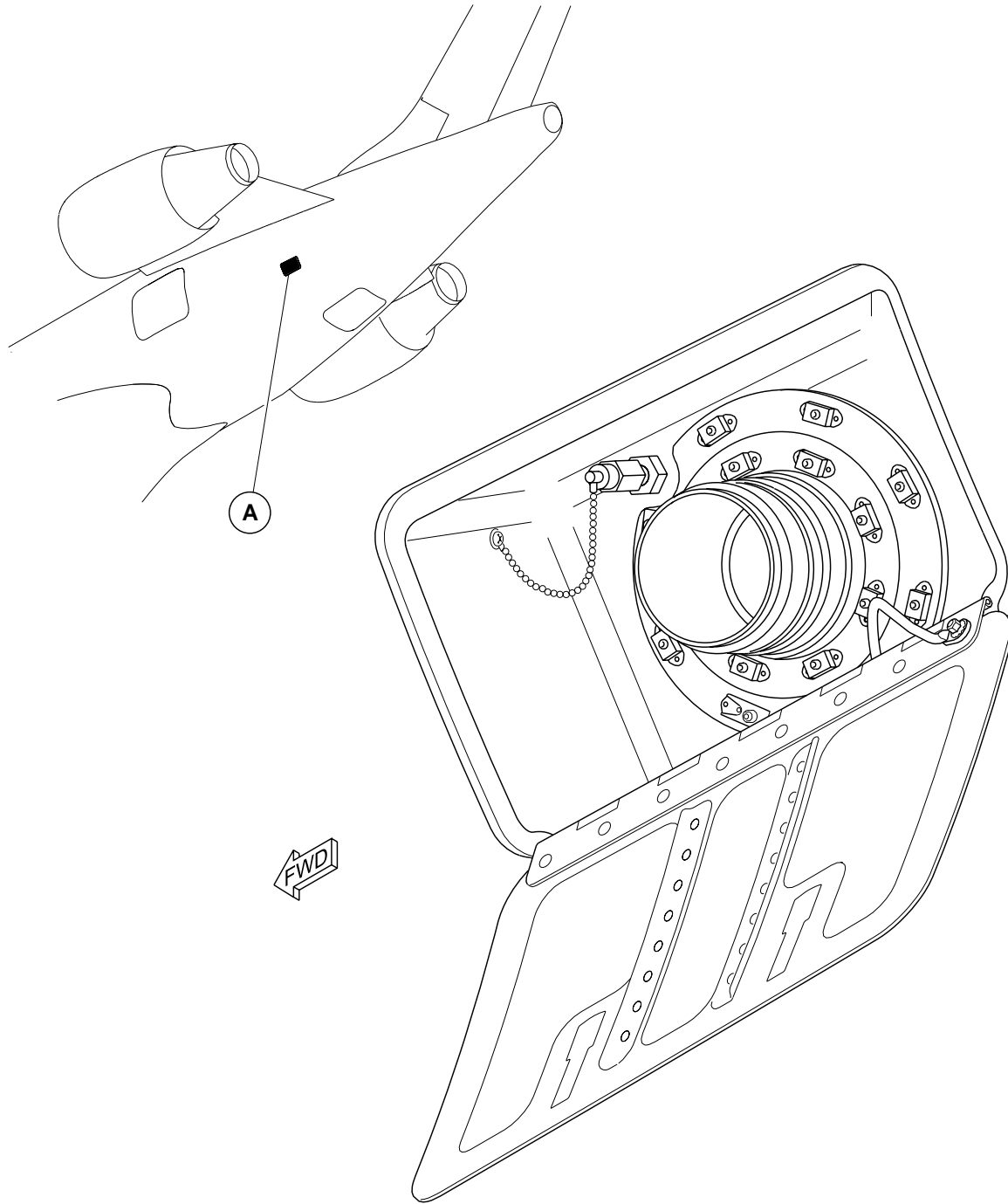

**A GROUND AIR CONNECTION**

babc6a01.cgm

Ground Air Supply  
Figure 12-20-00-000002

EFFECTIVITY: See first page of

TASK 12-20-00-001-A01

**12-20-00**

Page 4  
Jan 15/2005





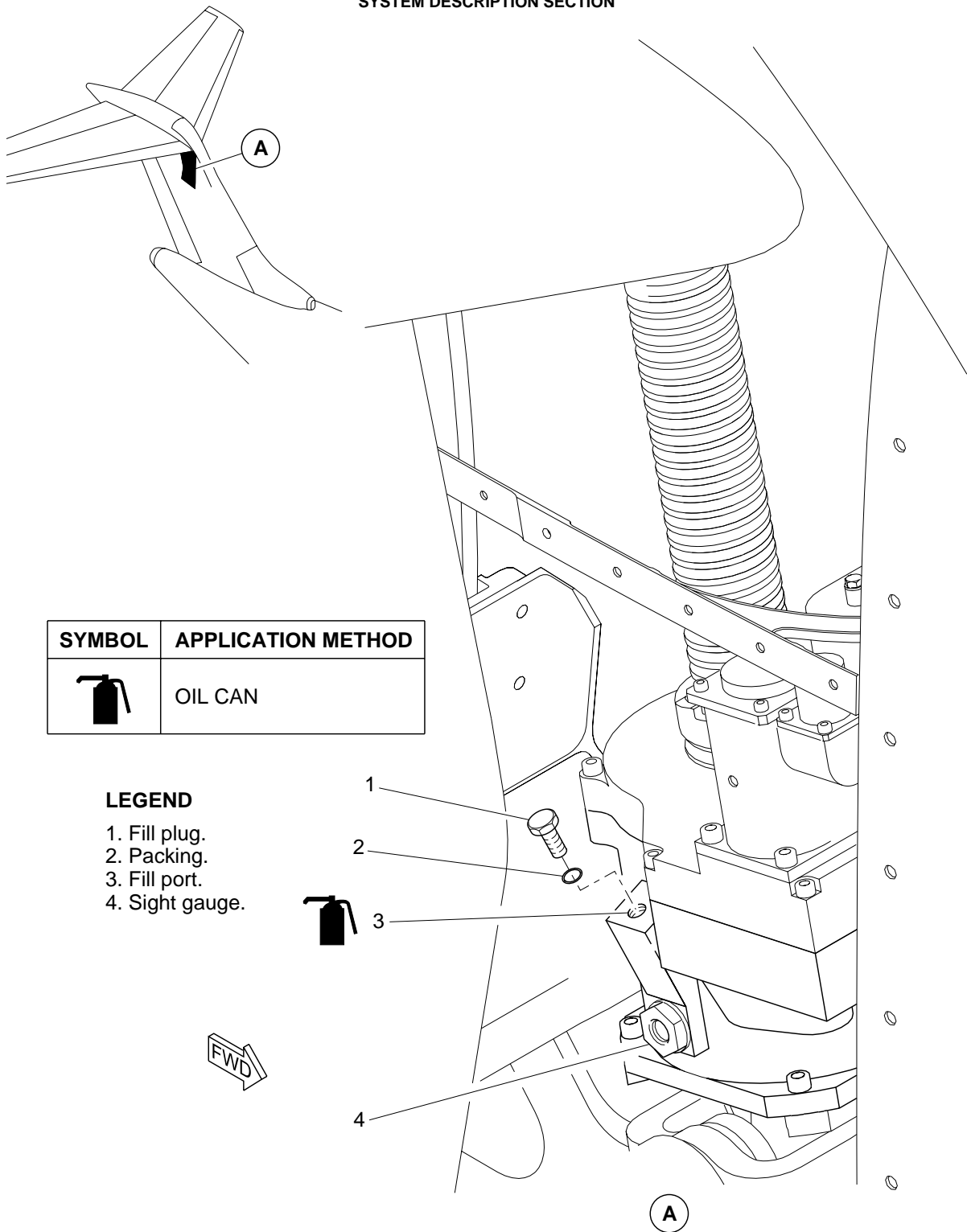

Horizontal Stabilizer Trim Actuator Oil System  
 Figure 12-20-00-000005

EFFECTIVITY: See first page of

TASK 12-20-00-001-A01

**12-20-00**

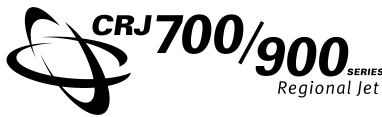

AIRCRAFT MAINTENANCE MANUAL - PART I  
SYSTEM DESCRIPTION SECTION

On A/C 15001-15990

## TASK 12-20-00-001-AA1 SCHEDULED SERVICING

### INTRODUCTION

The scheduled servicing procedures includes aircraft lubrication and cleaning. Scheduled servicing procedures also include tasks in the preventive maintenance schedule of the aircraft. Generally, these are the minimum standards established to make the aircraft airworthy. Operators can use higher approved standards to suit individual operations.

### GENERAL DESCRIPTION

Figures 12-20-00-000006, 12-20-00-000007, 12-20-00-000008, 12-20-00-000009 and 12-20-00-000010.

Scheduled servicing procedures include the tasks that follow:

- External and internal cleaning
- Lubrication

### AIRCRAFT CLEANING

The exterior of the aircraft must be washed and polished to prevent deterioration of the painted surfaces and corrosion of the polished surfaces. The interior surfaces, carpets and furnishings must also be cleaned frequently.

The servicing procedures give the approved materials, methods, and precautions for cleaning of the aircraft exterior, interior and the lavatory waste system.

Areas that require attention during cleaning are:

- Aircraft exterior
- Windshields
- Side windows
- Passenger windows
- Navigation light covers
- Anticollision light covers

- Landing/taxi light covers
- Aircraft internal surfaces and furnishings
- Floor coverings
- Toilet enclosure

### LUBRICATION

Mechanical components require regular lubrication to make sure they operation correctly and to prevent corrosion. Lubricants that are used include greases, aerosol lubricants, dry film lubricants and silicone compounds. Lubricants may be applied by grease gun, oil can, aerosol spray, brush or by hand application.

Aircraft areas that require regular lubrication include:

- Nose landing gear
- Nose landing gear doors
- Main landing gear
- Main landing gear doors
- Passenger door
- Galley service doors
- Baggage compartment doors
- Avionics compartment door
- Overwing emergency exits
- Horizontal stabilizer trim actuator
- Spoilers
- Flap and slat components
- Thrust reversers
- Air-driven generator

### TRAINING INFORMATION POINTS

- Always use approved window cleaning solutions and procedures.
- Before applying lubricants, make sure that the surface area is free of all dirt and moisture.
- Only use approved materials for servicing.

EFFECTIVITY: See first page of

TASK 12-20-00-001-AA1

12-20-00

Page 8  
Jan 15/2005

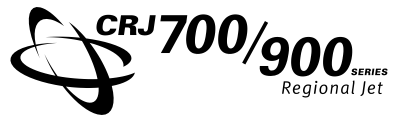

AIRCRAFT MAINTENANCE MANUAL - PART I  
SYSTEM DESCRIPTION SECTION

- Remove unwanted lubricants after servicing.
- Do a leak check if any fluid lines are replaced or disturbed.

EFFECTIVITY: See first page of

TASK 12-20-00-001-AA1

12-20-00

Page 9  
Jan 15/2005

**AIRCRAFT MAINTENANCE MANUAL - PART I**  
**SYSTEM DESCRIPTION SECTION**

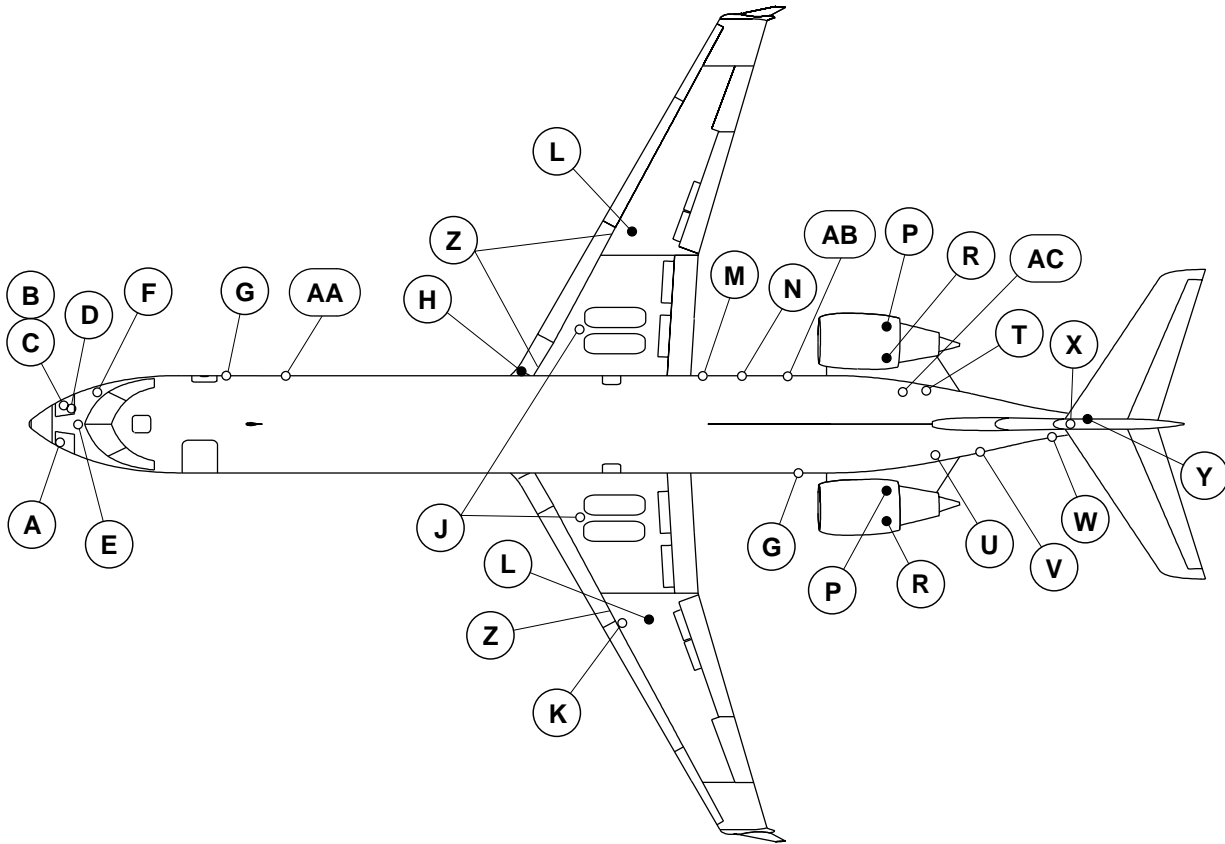

**LEGEND**

- Located on the lower side.
- Located on the upper side.
- A. Brake acc. charge.
- B. AC external power.
- C. Ground crew service panel with interphone.
- D. ADG oil servicing.
- E. NLG tire/oleo servicing/lubrication.
- F. Oxygen system charging valve & gauge.
- G. Potable Water servicing.
- H. Press. refuel/defuel panel & adapter.
- J. MLG tire/oleo servicing/lubrication.
- K. Fuel tank water drain (typical).
- L. Overwing gravity fuel filler.
- M. No. 3 hyd. sys. acc. charging pt., press. gauge & reservoir filler conn..
- N. AFT toilet servicing.
- P. Engine oil storage tank.
- R. IDG oil servicing.
- T. No. 2 hydraulic system accumulator / fill point.
- U. No. 1 hydraulic system accumulator & rear interphone / fill point.
- V. H.P. ground air servicing.
- W. APU servicing.
- X. Tail bumper servicing.
- Y. Horizontal stab. trim actuator oil servicing.
- Z. Wing grounding points.
- AA. Forward toilet servicing (optional).
- AB. L.P. air conditioning connection.
- AC. Single point oil replenishment system.

babd8a01.cgm

Aircraft Servicing - Locations  
 Figure 12-20-00-000006

EFFECTIVITY: See first page of

TASK 12-20-00-001-AA1

**12-20-00**

Page 10  
 Jan 15/2005



**AIRCRAFT MAINTENANCE MANUAL - PART I**  
**SYSTEM DESCRIPTION SECTION**

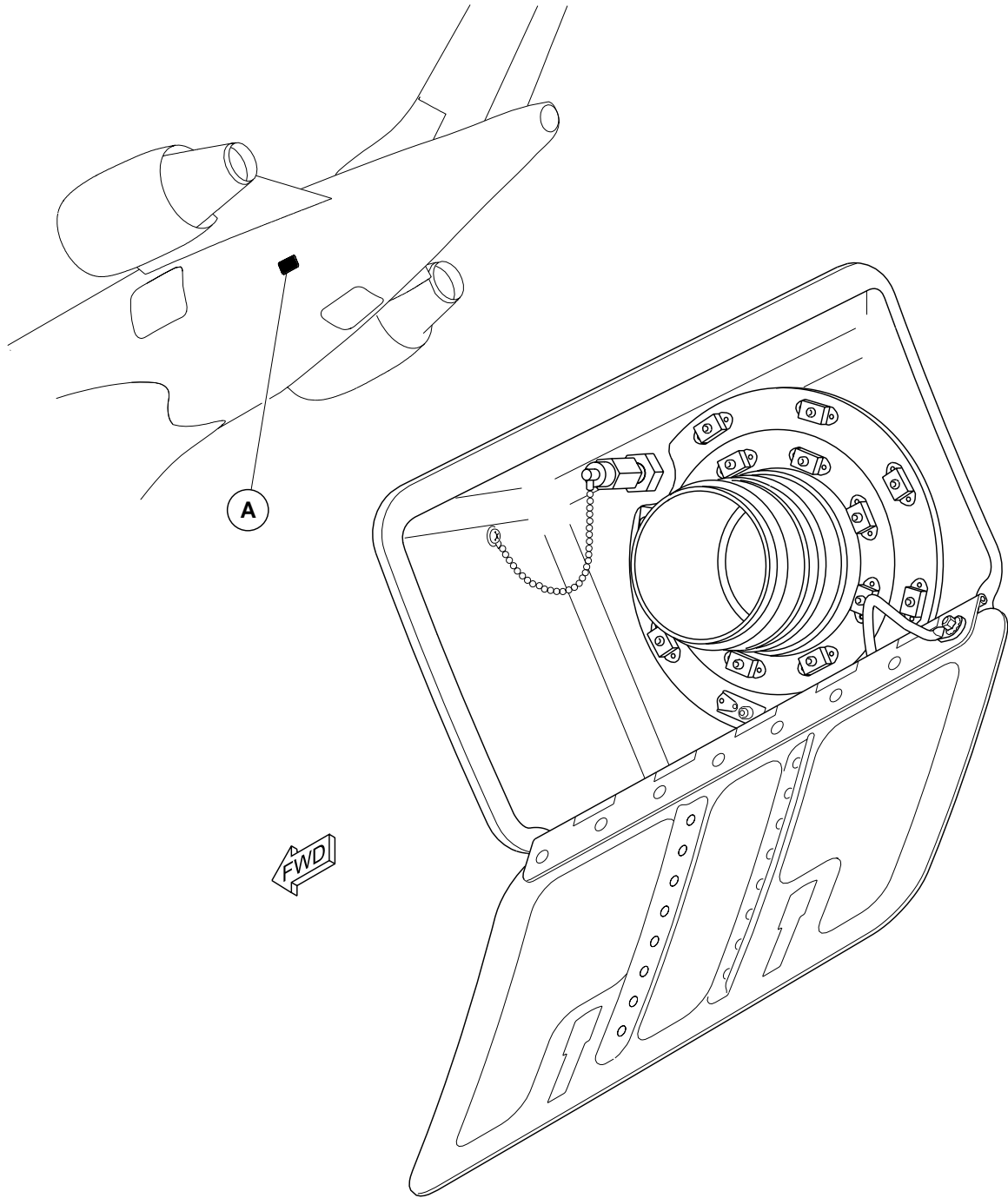

**A GROUND AIR CONNECTION**

Ground Air Supply  
Figure 12-20-00-000007

EFFECTIVITY: See first page of

TASK 12-20-00-001-AA1

**12-20-00**

Page 11  
Jan 15/2005

**AIRCRAFT MAINTENANCE MANUAL - PART I**  
**SYSTEM DESCRIPTION SECTION**

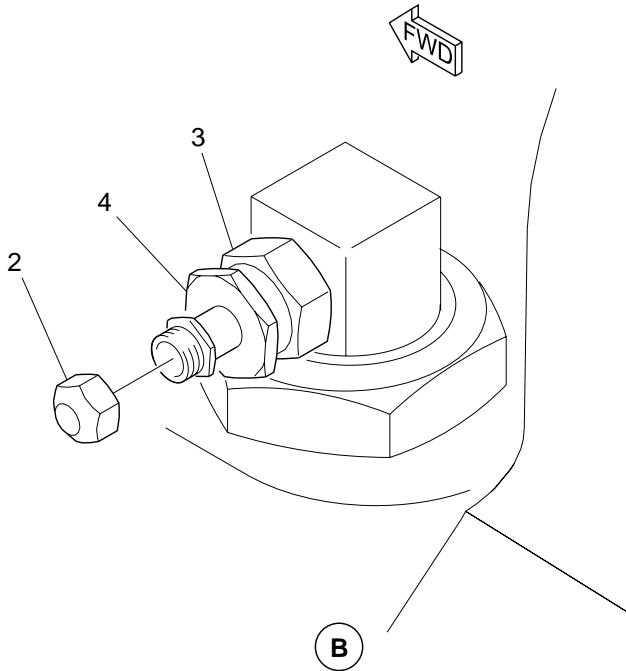
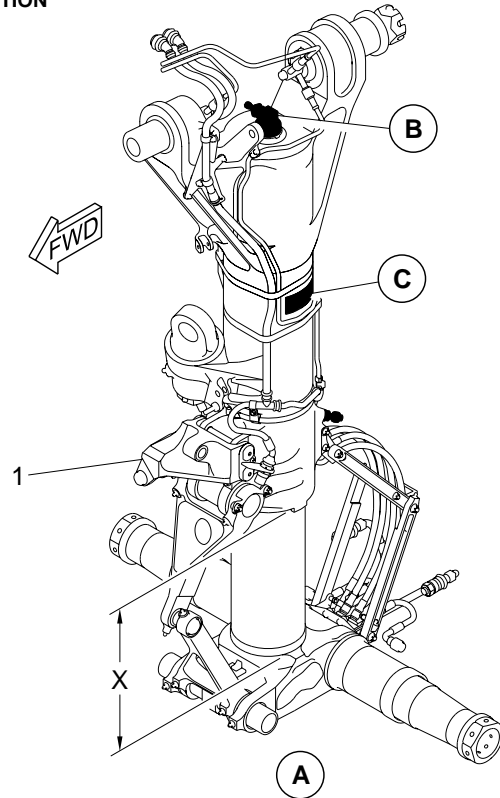
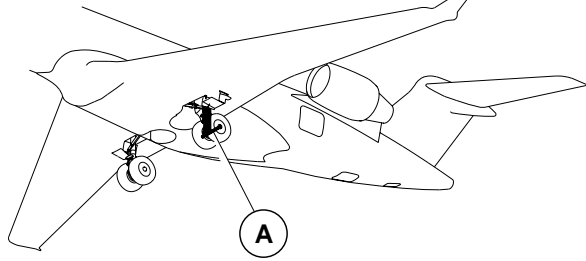

**LEGEND**

- 1. Strut.
- 2. Cap.
- 3. Charge valve.
- 4. Thin nut.

<p>DESIGNED AND MANUFACTURED BY: Coltec Industries</p> <p> MENASCO AEROSPACE OAKVILLE, ONTARIO, CANADA CAGE CODE 02121</p>	<p>FABRICATED BY:</p> <p> SUMITOMO PRECISION PRODUCTS AMAGASAKI, HYOGO, JAPAN CAGE CODE 0ABG4</p>	<p>FOR CRJ SERIES 700</p> <p>PART No. 49200-<input type="text"/></p> <p>SERIAL No. <input type="text"/></p> <p>ASSY DATE: <input type="text"/></p> <p>ENGINEERING SPEC : D-458 FLUID : MIL-H-5606</p>	<table border="1" style="width: 100%; border-collapse: collapse;"> <thead> <tr> <th colspan="2">MOD. STATUS</th> </tr> <tr> <th>S. B. NO.</th> <th>DATE</th> </tr> </thead> <tbody> <tr><td> </td><td> </td></tr> <tr><td> </td><td> </td></tr> <tr><td> </td><td> </td></tr> <tr><td> </td><td> </td></tr> <tr><td> </td><td> </td></tr> <tr><td> </td><td> </td></tr> <tr><td> </td><td> </td></tr> <tr><td> </td><td> </td></tr> <tr><td> </td><td> </td></tr> <tr><td> </td><td> </td></tr> </tbody> </table>	MOD. STATUS		S. B. NO.	DATE																				
MOD. STATUS																											
S. B. NO.	DATE																										
<p><b>SHOCK STRUT ASSY, MAIN LANDING GEAR</b></p>																											
<p><b>WARNING</b></p> <p>RELEASE NITROGEN PRESSURE IN STRUT THROUGH CHARGING VALVE BEFORE DISASSEMBLY</p> <p>MAINTENANCE WITH AIRCRAFT ON THE GROUND THE ACCEPTABLE PRESSURES ARE AS FOLLOWS:</p>																											
<p style="text-align: center;">NOTE: FULLY EXTENDED PRESSURE : 341.50 PSIG.</p>	<table border="1" style="width: 100%; border-collapse: collapse;"> <thead> <tr> <th>DIM. X INCHES</th> <th>PRESSURE PSI PSIG</th> </tr> </thead> <tbody> <tr><td>11</td><td>429</td></tr> <tr><td>10</td><td>469</td></tr> <tr><td>9</td><td>516</td></tr> <tr><td>8</td><td>574</td></tr> <tr><td>7</td><td>646</td></tr> <tr><td>6</td><td>737</td></tr> <tr><td>5</td><td>858</td></tr> <tr><td>4</td><td>1024</td></tr> <tr><td>3</td><td>1266</td></tr> <tr><td>2</td><td>1651</td></tr> <tr><td>1</td><td>2340</td></tr> </tbody> </table>	DIM. X INCHES	PRESSURE PSI PSIG	11	429	10	469	9	516	8	574	7	646	6	737	5	858	4	1024	3	1266	2	1651	1	2340	<p style="text-align: center;">INSTRUCTION FOR SERVICING</p> <ol style="list-style-type: none"> <li>1. REMOVE NITROGEN CHARGING VALVE CAP ATTACH OVERFLOW LINE TO CHARGE VALVE MS28889-2 AND OPEN CHARGE VALVE TO FULLY COMPRESS SHOCK STRUT.</li> <li>2. CONNECT MIL-H-5606 FLUID SUPPLY TO CHECK VALVE 1C1010 AND FILL STRUT WITH HYDRAULIC FLUID UNTIL NO BUBBLES ARE OBSERVED IN OVERFLOW LINE.</li> <li>3. REMOVE FLUID SUPPLY AND REPLACE BLANKING CAP ON CHECK VALVE.</li> <li>4. CONNECT NITROGEN SOURCE TO CHARGING VALVE AND PRESSURIZE STRUT TO OBTAIN VALUES SHOWN ON TABLE/GRAPH.</li> <li>5. CLOSE CHARGING VALVE. REMOVE NITROGEN SOURCE AND REPLACE CAP ON CHARGING VALVE.</li> </ol>	
DIM. X INCHES	PRESSURE PSI PSIG																										
11	429																										
10	469																										
9	516																										
8	574																										
7	646																										
6	737																										
5	858																										
4	1024																										
3	1266																										
2	1651																										
1	2340																										

**C**

**Main Landing Gear Shock Strut Extension**  
**Figure 12-20-00-000008**

EFFECTIVITY: See first page of

TASK 12-20-00-001-AA1

**12-20-00**

Page 12  
Jan 15/2005

babj8a01.cgm

**AIRCRAFT MAINTENANCE MANUAL - PART I**  
**SYSTEM DESCRIPTION SECTION**

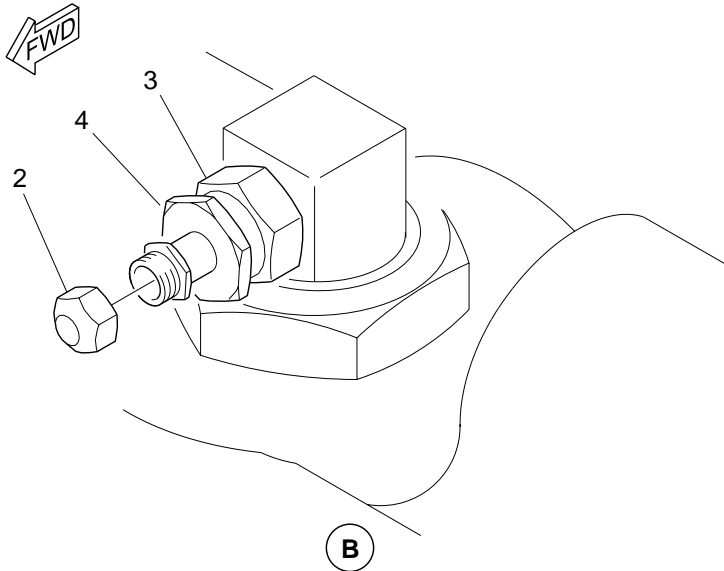
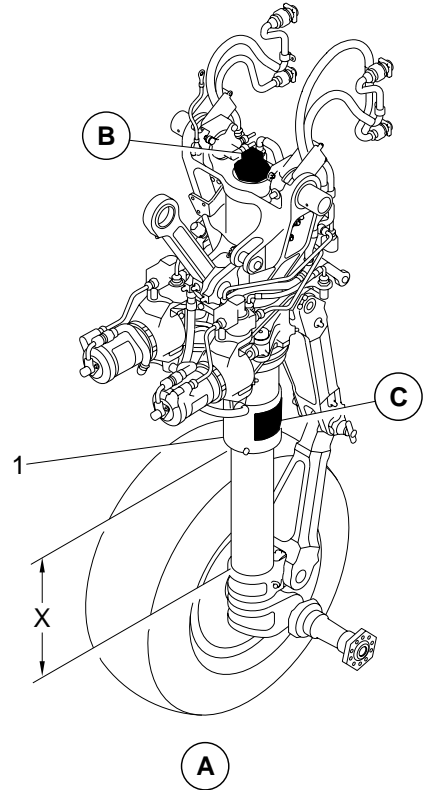
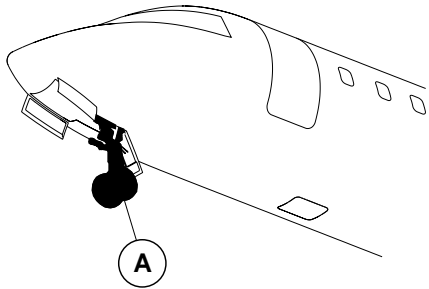

**LEGEND**

- 1. Strut.
- 2. Cap.
- 3. Charge valve.
- 4. Thin nut.

DESIGN AND MANUFACTURED BY: Coltec Industries MENASCO AEROSPACE OAKVILLE, ONTARIO, CANADA CAGE CODE 02121	FABRICATED BY: SUMITOMO PRECISION PRODUCTS AMAGASAKI, HYOGO, JAPAN CAGE CODE 0ABG4	SHOCK STRUT ASSY, NOSE LANDING GEAR FOR CRJ SERIES 700 PART No. 52100- <input style="width: 50px;" type="text"/> SERIAL No. <input style="width: 50px;" type="text"/> ASSY DATE: <input style="width: 50px;" type="text"/> ENGINEERING SPEC : D-459 FLUID : MIL-H-5606	<table border="1" style="width: 100%; border-collapse: collapse;"> <thead> <tr> <th colspan="2">MOD. STATUS</th> </tr> <tr> <th>S. B. NO.</th> <th>DATE</th> </tr> </thead> <tbody> <tr><td> </td><td> </td></tr> <tr><td> </td><td> </td></tr> <tr><td> </td><td> </td></tr> <tr><td> </td><td> </td></tr> <tr><td> </td><td> </td></tr> <tr><td> </td><td> </td></tr> <tr><td> </td><td> </td></tr> <tr><td> </td><td> </td></tr> <tr><td> </td><td> </td></tr> <tr><td> </td><td> </td></tr> </tbody> </table>	MOD. STATUS		S. B. NO.	DATE																				
MOD. STATUS																											
S. B. NO.	DATE																										
<b>WARNING</b>																											
RELEASE NITROGEN PRESSURE IN STRUT THROUGH CHARGING VALVE BEFORE DISASSEMBLY																											
MAINTENANCE : WITH AIRCRAFT ON THE GROUND THE ACCEPTABLE PRESSURES ARE AS FOLLOWS : <p style="font-size: small;">NOTE : FULLY EXTENDED PRESSURE 210 PSIG</p>	<table border="1" style="width: 100%; border-collapse: collapse;"> <thead> <tr> <th>DIM 'X' INCHES</th> <th>PRESSURE P<sub>25</sub> PSIG</th> </tr> </thead> <tbody> <tr><td>12</td><td>210</td></tr> <tr><td>11</td><td>230</td></tr> <tr><td>10</td><td>253</td></tr> <tr><td>9</td><td>282</td></tr> <tr><td>8</td><td>318</td></tr> <tr><td>7</td><td>363</td></tr> <tr><td>6</td><td>422</td></tr> <tr><td>5</td><td>503</td></tr> <tr><td>4</td><td>621</td></tr> <tr><td>3</td><td>808</td></tr> <tr><td>2</td><td>1142</td></tr> </tbody> </table>	DIM 'X' INCHES	PRESSURE P <sub>25</sub> PSIG	12	210	11	230	10	253	9	282	8	318	7	363	6	422	5	503	4	621	3	808	2	1142	INSTRUCTION FOR SERVICING 1. ATTACH OVERFLOW LINE TO CHARGE VALVE MS28889-2 AND OPEN CHARGE VALVE TO FULLY COMPRESS SHOCK STRUT. 2. CONNECT MIL-H-5606 FLUID SUPPLY TO CHECK VALVE 1C1010 AND FILL STRUT WITH HYDRAULIC FLUID UNTIL NO BUBBLES ARE OBSERVED IN OVERFLOW LINE. 3. REMOVE FLUID SUPPLY AND REPLACE BLANKING CAP ON CHECK VALVE. 4. CONNECT NITROGEN SOURCE TO CHARGING VALVE AND PRESSURIZE STRUT TO OBTAIN VALVES SHOWN ON TABLE/GRAPH. 5. CLOSE CHARGING VALVE. REMOVE NITROGEN SOURCE AND REPLACE CAP ON CHARGING VALVE.	
DIM 'X' INCHES	PRESSURE P <sub>25</sub> PSIG																										
12	210																										
11	230																										
10	253																										
9	282																										
8	318																										
7	363																										
6	422																										
5	503																										
4	621																										
3	808																										
2	1142																										

C

**Nose Landing Gear Shock Strut**  
 Figure 12-20-00-000009

EFFECTIVITY: See first page of  
 TASK 12-20-00-001-AA1

babj9e01.cgm

**AIRCRAFT MAINTENANCE MANUAL - PART I**  
**SYSTEM DESCRIPTION SECTION**

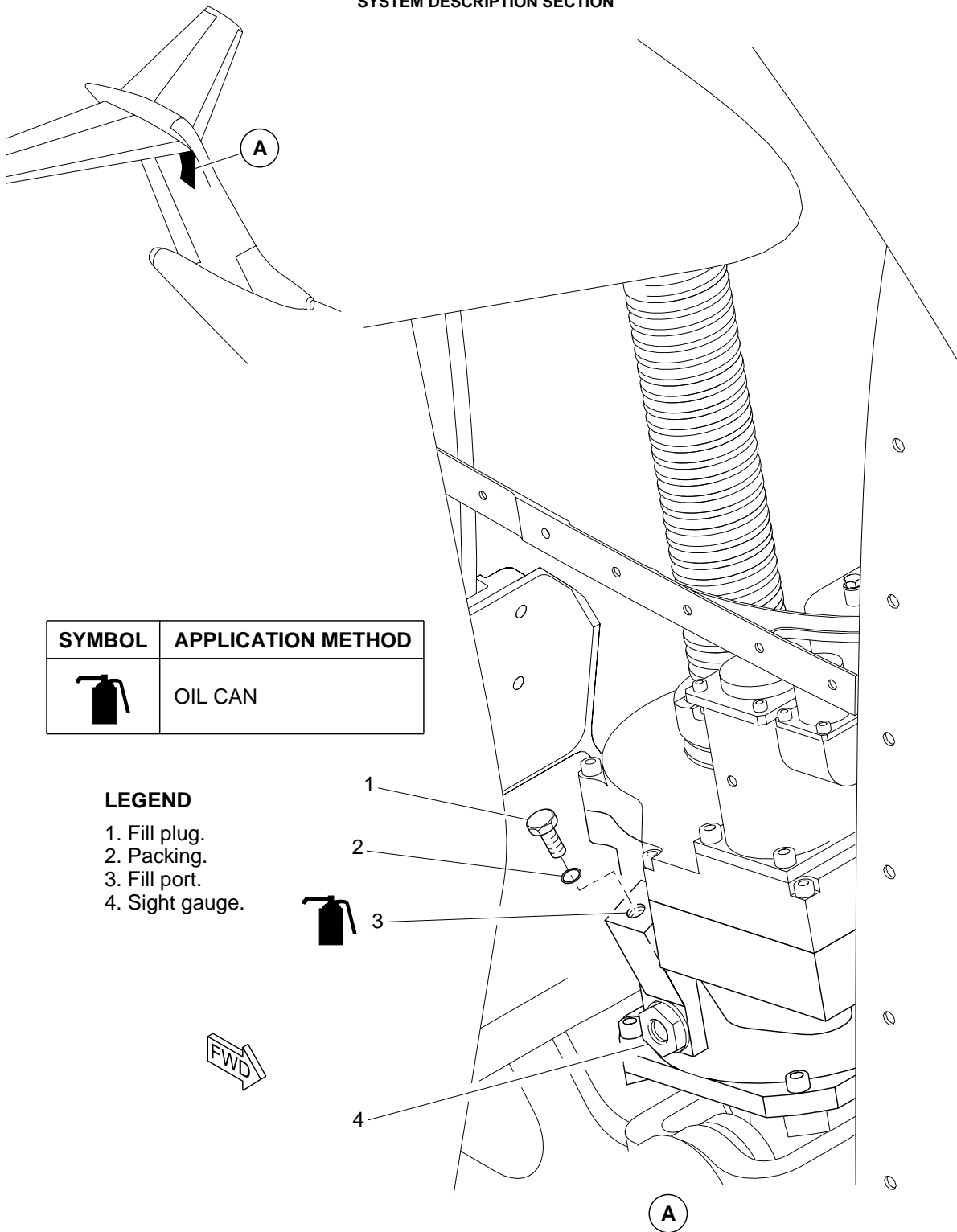

babk1a01.cgm

Horizontal Stabilizer Trim Actuator Oil System  
 Figure 12-20-00-000010

EFFECTIVITY: See first page of

TASK 12-20-00-001-AA1

**12-20-00**

Page 14  
 Jan 15/2005

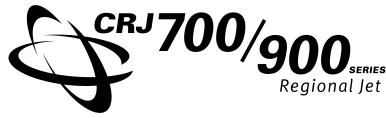

AIRCRAFT MAINTENANCE MANUAL - PART I  
SYSTEM DESCRIPTION SECTION

On A/C 10001-10999, 15001-15990

## **TASK 12-30-00-001-A01 UNSCHEDULED SERVICING**

### **INTRODUCTION**

The unscheduled servicing of the aircraft includes the servicing procedures that follow:

- Cold weather parking
- Snow removal
- Aircraft deicing/anti-icing standard practices

Cold weather protection includes the procedures and precautions necessary to prevent damage to the aircraft caused by cold temperatures.

### **GENERAL DESCRIPTION**

#### **COLD WEATHER PARKING**

Special precautions must be taken when the aircraft is parked in an open area during cold weather. If the aircraft is parked for more than seven days in cold weather, additional precautions must be taken.

#### **SNOW REMOVAL**

Accumulated snow must be removed from the aircraft structure and adjacent area when:

- The depth of the snow is more than permitted limits on the aircraft wings, horizontal stabilizer or fuselage
- Higher than usual temperatures cause freezing rain or melted snow
- The depth of the snow below and around the aircraft prevents the regular inspection of the aircraft
- It is necessary to move the aircraft

### **AIRCRAFT DEICING/ANTI-ICING STANDARD PRACTICES**

Industry and regulatory agencies issue information, precautions and standard practices to prevent snow, ice, and frost from accumulating on the aircraft. The operator must use the correct procedures for the ambient weather conditions. This must include deicing and anti-icing.

Aircraft deicing is to be done to remove frost, ice or snow that collects on the aircraft surfaces.

Aircraft anti-icing is done using an anti-icing fluid mixture applied to the aircraft surfaces. This is done to make sure that ice, snow or frost does not collect on the aircraft surfaces.

### **TRAINING INFORMATION POINTS**

Obey all safety precautions, when deicing the aircraft with the APU air intake door open. If the APU is in operation, the entry of deicing fluid may cause the APU to shut down or may cause contamination of the passenger compartment conditioned air system.

EFFECTIVITY: See first page of

TASK 12-30-00-001-A01

**12-30-00**

Page 1  
Jan 15/2005

